

## Peddiworker



### Profilstahlmesser zum Schneiden von Winkelstahl 90°, Rund- und Vierkantstahl

Section shear knives for straight shearing angle iron, rounds and squares

Couteaux à profilés pour couper les cornières à 90°, et ronds et carrés  
Profielstaalmessen tbv knippen van hoekstaal, rond- en vierkant-staal

Kenn-Nr. **601**  
Ref. No.  
No. de réf.

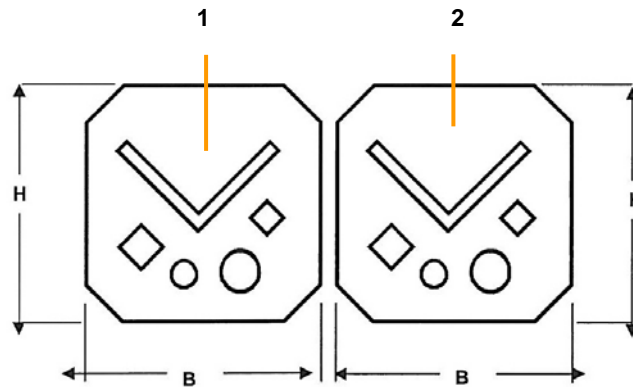

**1**  
**Messerplatte, beweglich**  
shear blade, moveable  
lame de coupe mobile  
profielstaalmes bewegend

**2**  
**Messerplatte, fest**  
shear blade, stationary  
lame de coupe fixe  
profielstaalmes vast

Peddiworker		H	B	S	Artikel-Nr. part no. no. de réf. Bestelnr.	Profilstahlmesser, Satz section shear knives, set lames de coupe, jeu Profielstaalmessenset	
No. 1 802	1	245	240	35	40629 5 4302 00	40629 5 4300 00	
	2	255	243	38	44225 5 4301 00		
502	1	195	195	25	40616 5 1201 00	40616 5 1200 00	
	2	200	200	25	40616 5 1202 00		
Peddiworker		H	B	S	Artikel-Nr. part no. no. de réf.	Stabstahlmesser, Satz barshear knives, set lames à ronds+carrés, jeu	
500 501 800 801		1	100	95	25	40620 5 4302 00	40620 5 4300 00
		2	100	100	25	40620 5 4301 00	

# Peddiworker



## Winkelstahlmesser 90° und 45°

Section shear knives for straight+mitre shearing angle iron  
 Couteaux à profilés pour couper les cornières à 90° et à 45°  
 Profielstaalmessen tbv knippen von hoekstaal 90° en 45°

Kenn-Nr.  
 Ref. No.  
 No. de réf.

201

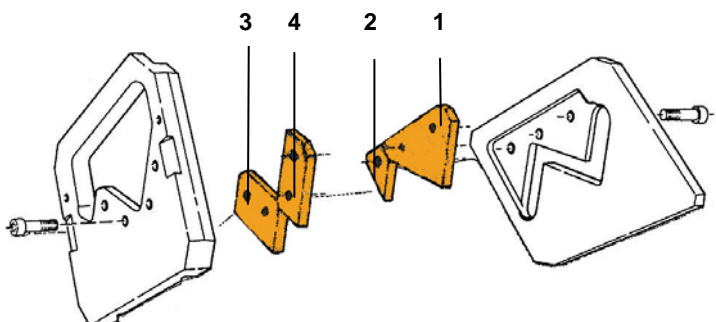

Peddiworker	Bezeichnung	Description	Description	Artikel-Nr. part no. no. de réf.
600 800 801	1 Dreieckmesser bewegl.	triangular blade moveable	lame triangulaire mobile	44001 5 1170 11
	2 Dreieckmesser, klein	triangular blade, small	lame triangulaire petite	44001 5 1170 12
	3 waager. Messer, fest	horizontal blade, station.	lame horizontale fixe	44001 5 1170 13
	4 senkr. Messer, fest	vertical blade, stationary	lame verticale fixe	44001 5 1170 14
	Einsatzmesser, Satz	insert blades, set	lames de coupe, jeu	44001 5 1170 10
1000 1000 G	1 Dreieckmesser bewegl.	triangular blade moveable	lame triangulaire mobile	44041 5 1170 11
	2 Dreieckmesser, klein	triangular blade, small	lame triangulaire petite	44041 5 1170 12
	3 waager. Messer, fest	horizontal blade, station.	lame horizontale fixe	44041 5 1170 13
	4 senkr. Messer, fest	vertical blade, stationary	lame verticale fixe	44041 5 1170 14
	Einsatzmesser, Satz	insert blades, set	lames de coupe, jeu	44041 5 1170 10

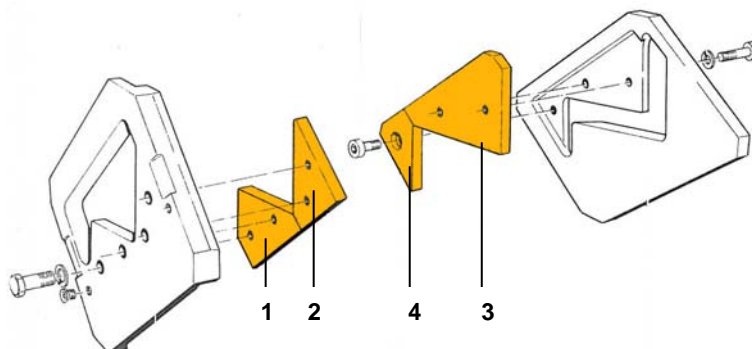

Peddiworker	Bezeichnung	Description	Description	Artikel-Nr. part no. no. de réf.
400 500 501	1 Dreieckmesser, gr. fest	triangular blade, large, stat.	lame triangulaire, fixe	40611 5 2502
	2 Dreieckmesser, kl. fest	triangular blade, small, stat.	lame triangulaire, fixe	40611 5 2503
	3 Dreieckmesser, gr. bew.	triangular blade, large, mov.	lame triangulaire, mob.	40611 5 2506
	4 Dreieckmesser, kl. bew.	triangular blade, small mov.	lame triangulaire, mob.	40611 5 2507
	Einsatzmesser, Satz	insert blades, set	lames de coupe, jeu	40611 5 2500 10



## Peddiworker



**Profilstahlmesser Z1, handverstellbar**  
Section shear knives Z1, manually adjustable  
Couteaux à profilés Z1, manuellement réglables  
Profielstaalmessen Z1, handmatig instelbaar

Kenn-Nr. **202**  
Ref. No.  
No. de réf.

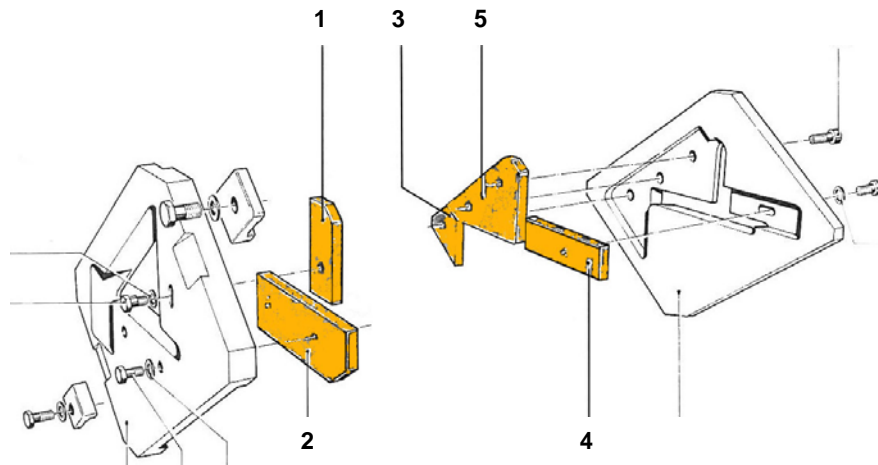

Peddiworker	Bezeichnung	Description	Description	Artikel-Nr. part no. no. de réf.
<b>400</b>	1 Schiebemesser, senkr.	sliding blade vertical	lame coulissante vert.	40600 5 1152
	2 Messer, waagrecht	insert blade, horizontal	lame horizontale	40600 5 1157
<b>500</b>	3 Dreieckmesser, klein	triangular blade, small	lame triangulaire petite	40600 5 1158
<b>501</b>	4 Untermesser, waager.	lower blade, horizontal	lame inférieure horiz.	40600 5 1153
	5 Dreieckmesser, groß	triangular blade, large	lame triangulaire grande	40600 5 1159
	Einsatzmesser, Satz	insert blades, set	lames de coupe, jeu	40600 5 1160 10
<b>600</b>	1 Schiebemesser, senkr.	sliding blade vertical	lame coulissante vert.	44001 5 1152
	2 Messer, waagrecht	insert blade, horizontal	lame horizontale	44001 5 1157
<b>800</b>	3 Dreieckmesser, klein	triangular blade, small	lame triangulaire petite	44001 5 1158
	4 Untermesser, waager.	lower blade, horizontal	lame inférieure horiz.	44001 5 1160 03
	5 Dreieckmesser, groß	triangular blade, large	lame triangulaire grande	44001 5 1160 04
	Einsatzmesser, Satz	insert blades, set	lames de coupe, jeu	44001 5 1160 10
<b>1000</b>	1 Schiebemesser, senkr.	sliding blade vertical	lame coulissante vert.	44041 5 1160 05
	2 Messer, waagrecht	insert blade, horizontal	lame horizontale	44041 5 1157
<b>1000 G</b>	3 Dreieckmesser, klein	triangular blade, small	lame triangulaire petite	44041 5 1158
	4 Untermesser, waager.	lower blade, horizontal	lame inférieure horiz.	44041 5 1160 03
	5 Dreieckmesser, groß	triangular blade, large	lame triangulaire grande	44041 5 1160 04
	Einsatzmesser, Satz	insert blades, set	lames de coupe, jeu	44041 5 1160 10