

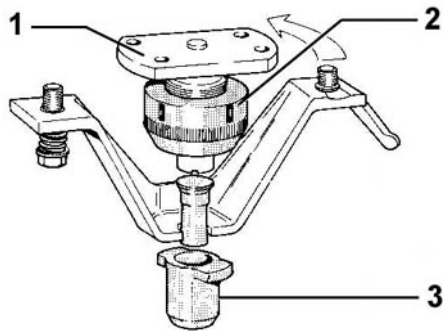

## Dispositivo de cambio rápido de punzonado

## 210 Super • 210 Forax • Stanzfix 225 B



210 Super 11, 13 225 B 13, 16 Forax 15, 25, 45, 65, 150, 250, 450 Stanzfix	210 Super 16, 20 225 B 80, 100 Forax 80, 100, 1000	210 Super 25 225 B 130
--	--	---------------------------

### Serie roja



No. 1  
No. 4

hasta Ø 27 mm

### Serie verde



No. 2  
No. 5

hasta Ø 32 mm

### Serie azul



No. 3  
No. 6

hasta Ø 39 mm

	Descripción	No. ref.	No. ref.	No. ref.																
	1 portapunzón	44001 199 990	44081 199 990	44161 199 990																
		<table border="1"> <tr><td>A</td><td>B</td><td>C</td></tr> <tr><td>71</td><td>32</td><td>28</td></tr> </table>	A	B	C	71	32	28	<table border="1"> <tr><td>A</td><td>B</td><td>C</td></tr> <tr><td>100</td><td>37</td><td>47</td></tr> </table>	A	B	C	100	37	47	<table border="1"> <tr><td>A</td><td>B</td><td>C</td></tr> <tr><td>109</td><td>45</td><td>50</td></tr> </table>	A	B	C	109
A	B	C																		
71	32	28																		
A	B	C																		
100	37	47																		
A	B	C																		
109	45	50																		
	2 tuerca tensora rápida	44001 198 991	44081 198 991	44161 198 991																
		<table border="1"> <tr><td>A</td><td>B</td><td>C</td></tr> <tr><td>38</td><td>70</td><td>45,5</td></tr> </table>	A	B	C	38	70	45,5	<table border="1"> <tr><td>A</td><td>B</td><td>C</td></tr> <tr><td>45</td><td>85</td><td>52,5</td></tr> </table>	A	B	C	45	85	52,5	<table border="1"> <tr><td>A</td><td>B</td><td>C</td></tr> <tr><td>55</td><td>100</td><td>60,5</td></tr> </table>	A	B	C	55
A	B	C																		
38	70	45,5																		
A	B	C																		
45	85	52,5																		
A	B	C																		
55	100	60,5																		
	3 tensor rápido	44001 198 992	44081 198 992	44161 198 992																
		<table border="1"> <tr><td>A</td><td>B</td><td>C</td></tr> <tr><td>44</td><td>27,1</td><td>45</td></tr> </table>	A	B	C	44	27,1	45	<table border="1"> <tr><td>A</td><td>B</td><td>C</td></tr> <tr><td>60</td><td>32,2</td><td>52</td></tr> </table>	A	B	C	60	32,2	52	<table border="1"> <tr><td>A</td><td>B</td><td>C</td></tr> <tr><td>62</td><td>39,7</td><td>60</td></tr> </table>	A	B	C	62
A	B	C																		
44	27,1	45																		
A	B	C																		
60	32,2	52																		
A	B	C																		
62	39,7	60																		



tensor rápido especial



No. 5

para punzón para  
cerradura

44081 6 2928 03



tensor rápido especial

44001 6 3523 01

65004 8087 01

44001 6 3503 03



No. 4  
de gran  
tamaño



Ø 28 – 29 – 30 mm



□ 20 – 21 mm



L = 28 – 30 mm