



Peddinghaus

Peddinghaus Anlagen & Maschinen GmbH



Stanzwerkzeuge

Punching Tools

Outils de poinçonnage

Katalog

7





Peddinghaus Anlagen & Maschinen GmbH

Peddinghaus Anlagen & Maschinen GmbH
Hasslinghauser Str. 156 • D-58285 Gevelsberg
Tel. +49 (0) 2332 / 6646-21/22/23
Fax +49 (0) 2332 / 6646-46
teile-pam@peddy.de • www.peddy.de

Inhalt	Content	Index	Seite/page
Grüne Serie für die Stempel-Schnellwechsellvorrichtung, heutige Generation	Green Series for the quick-change punching attachment, current steelworker range	Série verte pour le dispositif de serrage rapide du poinçon de de nos poinçonneuses actuelles	 3
Rote Serie für die Stempel-Schnellwechsellvorrichtung der älteren Modellreihen	Red Series for the quick-change punching attachment of past machine generations	Série rouge pour le dispositif de serrage rapide du poinçon des gammes de machines anciennes	 10
Blaue Serie für alle Sonder-Stanzvorrichtungen, heutige Generation + ältere Modelle	Blue Series for all oversize punching attachments, current and past generations	Série bleue pour les dispositifs de poinçonnage grand diamètre, générations actuelle et anciennes	 16
Werkzeugsortimente Stempel & Matrizen	Tooling sets punches & dies	Assortiments d'outils poinçons & matrices	 24
Sonder-Stanzwerkzeuge	Special punching tools	Outils de poinçonnage spéciaux	 26
U.S. - Norm für CNC-Stanzanlagen AFPS • AFCPS • APS • FPDB • FPB • FPD 1120 • F-1170	U.S. - Style for CNC punching lines	Type américain pour lignes de poinçonnage à commande numérique	 32
Mubea Norm	Mubea Style	Type Mubea	 37
Peddy • Peddicat 275H • 21/16 • 36 RP 10			 43
Handhebel-Lochstanzen	Hand-lever punching machines	Poinçonneuses à levier	 47
Elemente der Stanzvorrichtungen	Elements of punching attachments	Dispositifs de poinçonnage - éléments	 51
Stanzvorrichtungen für Exzenterpressen	Punching attachment for eccentric press	Dispositifs pour presses excentriques	69
Technische Daten	Technical Data	Données techniques	71



ORIGINAL-Peddinghaus Stempel und Matrizen aus eigener Fertigung

Seit über sechzig Jahren bietet Peddinghaus Norm-Stanzwerkzeuge in der gleichen Form, aber heute in einer wesentlich besseren Qualität und mit engeren Fertigungstoleranzen.

Sie erhalten deshalb auch für eine Peddinghaus-Maschine, die sechs Jahrzehnte alt ist – und das ist nicht selten – passende Stempel und Matrizen ab Lager, damit Sie sicher produzieren können.

Peddinghaus-Stempel und -Matrizen werden auf höchstem technischen Niveau produziert. Dafür wurde eine moderne Spezialfertigung eingerichtet und ein Qualitätssicherungssystem aufgebaut.

Jeder Stempel, jede Matrize wird sorgfältig aus hochwertigem Werkzeugstahl hergestellt und gehärtet. Peddinghaus ist Spezialist für Härtetechnik, die selbstverständlich für alle Stanzwerkzeuge genutzt wird, z. B. für Werkzeugaufnahmen, Vorrichtungen, Anschlag- und Meßeinrichtungen, Auflagetische, kurz das, was Sie bei Ihrer Arbeit einen entscheidenden Schritt nach vorne bringt.

Das gute Preis-Leistungsverhältnis und die Fachkompetenz in allen Werkzeugfragen werden seit Jahrzehnten von vielen tausend zufriedenen Kunden genutzt.

Peddinghaus fertigt alle Werkzeuge und Teile selbst.

ORIGINAL Peddinghaus Punches and dies made by Peddinghaus

Peddinghaus has been supplying standard punching tools of the same style for more than sixty years, nowadays, however of significantly improved quality with closer machining tolerances.

This means that you can obtain punches and dies ex stock even for a sixty years old Peddinghaus machine – and this is no rare case – enabling you to produce reliably.

Peddinghaus punches and dies are produced by state-of-the-art technology.

Each punch and each die is manufactured with care from high-grade tool steel and hardened.

Peddinghaus is a specialist in hardening technology which is of course implemented in the production of the punching tools as well as all attachments, gauging and measuring equipment, ledge tables - in short for everything which will take you a significant step ahead in your production.

Many thousands of customers have made use for decades to their satisfaction of the price/performance ratio and the qualified assistance in solving their tooling questions.

All tools and parts are manufactured by Peddinghaus

Poinçons et matrices de fabrication ORIGINAL Peddinghaus

Depuis plus de soixante ans, Peddinghaus fournit des outils de poinçonnage normalisés, de type identique, aujourd'hui toutefois d'une qualité nettement améliorée avec des tolérances de fabrication plus étroites.

Il est ainsi possible d'obtenir à partir de notre stock les poinçons et les matrices d'une machine Peddinghaus âgée de soixante ans – ce cas n'est pas rare - ce qui permet d'assurer une production ininterrompue chez nos clients.

Les poinçons et matrices Peddinghaus sont fabriqués au plus haut niveau technique. Chaque poinçon et chaque matrice est fabriqué de manière minutieuse à partir d'un acier à outils de qualité supérieure puis trempé. Chez Peddinghaus, nous sommes spécialisés dans la technologie de la trempe, ce qui profite bien-entendu à tous les outils de poinçonnage, porte-outils, dispositifs, équipements de butée et de mesurage, tables de support – bref à tout ce qui vous fait avancer d'une manière décisive dans votre travail.

Une bonne relation prix-qualité et une assistance qualifiée pour toute question concernant l'outillage, c'est ce qu'apprécient plusieurs milliers de nos clients depuis des décennies.

Chaque outil et chaque pièce est fabriqué par Peddinghaus.

Service

Nutzen Sie den Peddinghaus-Fachservice und den Expressdienst für sofortige Lieferung. Wir verfügen über ein großes Ersatzteillager für alle bisher gelieferten Peddinghaus-Maschinen. Auch für ältere Maschinen mit mechanischem Antrieb bedienen wir unsere Kunden mit Ersatzteilen.

Als Hersteller der weltbekannten Lochstanzen und Profilstahlscheren bieten wir Ihnen in der Teile-Versorgung viele Vorteile:

- kostenlose telefonische Kundendienstbetreuung
- Ersatzteilfindung per Telefon
- praxisnahe Beratung



Tel. +49 (0) 2332 – 6646-15
Fax +49 (0) 2332 – 6646-46
Email: service@peddy.de



Grüne Serie • Green Series • Série verte

für Modelle der heutigen Generation:
for machines of the current generation:
pour machines de la génération actuelle:

Peddibasic No. 1
Peddicat No. 1
Peddiworker No. 1

Hydraulic 280
Hydraulic 502
Hydraulic 801

für ältere Modelle:
for older machine types:
pour modèles plus anciens:

Peddicat 361 • 380 • 500
Peddiworker 501 • 502 • 801 • 802 • 1000 G
Peddimaster 100/160 • 110/170 • 800/1100 • 1100/1700
Peddimax 600 • 601 • 602 • 800 • 801 • 1002 • 110/140
Hydraulic 100 • 301 • 501 • 800 • 1000 • 1001
210 Super 16 • 20, 210 Standard 16
Forax 80 • 100 • 1000
225 B/16 • 20 • 80 • 100
225 H/15 • 20

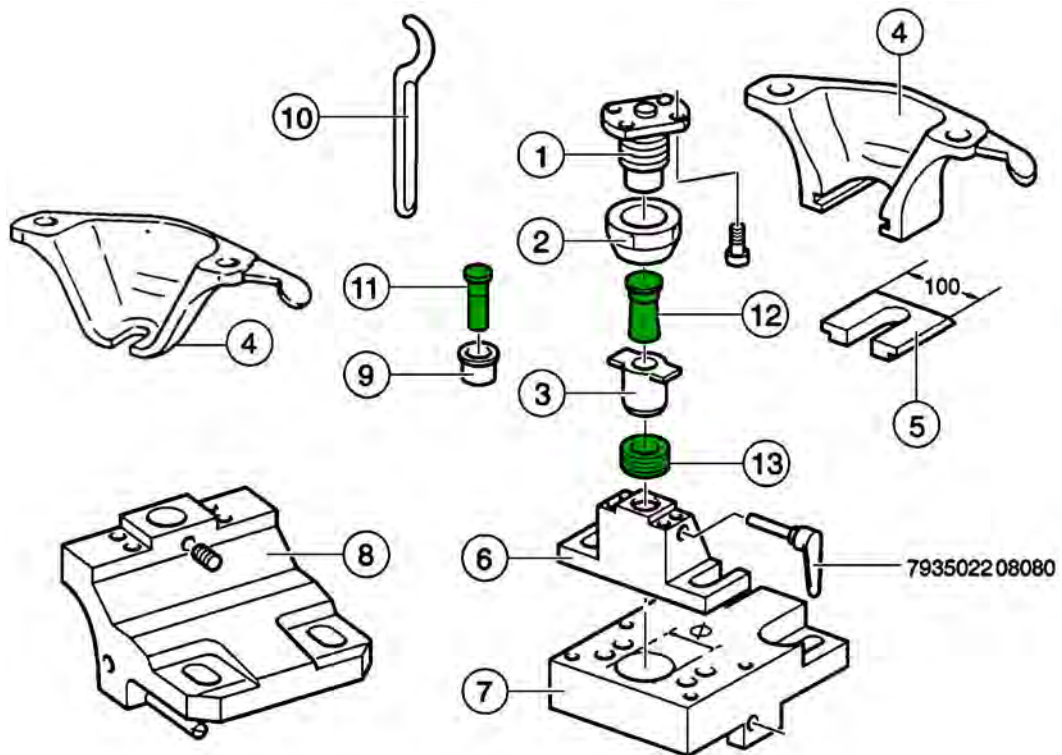

Stempel und Matrizen zur Schnellwechsellvorrichtung
Punches and dies for the quick-change punching attachment
Poinçons et matrices pour utilisation dans le dispositif de serrage rapide du poinçon

Grüne Serie • Green Series • Série verte

Rundstempel
 round punch
 poinçon rond

Rundstempel
 round punch
 poinçon rond

Rundmatrize
 round die
 matrice ronde

Rundmatrize
 round die
 matrice ronde

Winkelstahlmatrize
 offset flat die
 matrice ronde décentrée

Nr. 2

Nr. 5

Nr. 3

Nr. 3

Nr. 14

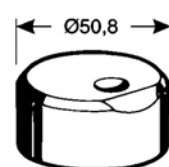
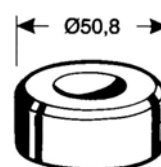
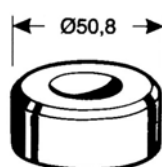
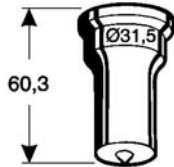
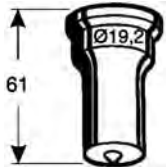

Artikel-Nr.	Artikel-Nr.	Artikel-Nr.	Artikel-Nr.	Artikel-Nr.					
3,0	64002 1030	17,5	64005 1175	3,2	64203 1032	20,2	64203 1202	5,7	64214 1057
3,2	64002 1032	18,0	64005 1180	3,4	64203 1034	20,7	64203 1207	6,2	64214 1062
3,5	64002 1035	18,5	64005 1185	3,7	64203 1037	21,2	64203 1212	6,7	64214 1067
4,0	64002 1040	19,0	64005 1190	4,2	64203 1042	21,7	64203 1217	7,2	64214 1072
4,2	64002 1042	19,5	64005 1195	4,4	64203 1044	22,2	64203 1222	7,7	64214 1077
4,5	64002 1045	20,0	64005 1200	4,7	64203 1047	22,7	64203 1227	8,2	64214 1082
5,0	64002 1050	20,5	64005 1205	5,2	64203 1052	23,2	64203 1232	8,7	64214 1087
5,5	64002 1055	21,0	64005 1210	5,7	64203 1057	23,7	64203 1237	9,2	64214 1092
6,0	64002 1060	21,5	64005 1215	6,2	64203 1062	24,2	64203 1242	9,7	64214 1097
6,5	64002 1065	22,0	64005 1220	6,7	64203 1067	24,7	64203 1247	10,2	64214 1102
7,0	64002 1070	22,5	64005 1225	7,2	64203 1072	25,2	64203 1252	10,7	64214 1107
7,5	64002 1075	23,0	64005 1230	7,7	64203 1077	25,7	64203 1257	11,2	64214 1112
8,0	64002 1080	23,5	64005 1235	8,2	64203 1082	26,2	64203 1262	11,7	64214 1117
8,5	64002 1085	24,0	64005 1240	8,7	64203 1087	26,7	64203 1267	12,2	64214 1122
9,0	64002 1090	24,5	64005 1245	9,2	64203 1092	27,2	64203 1272	12,7	64214 1127
9,5	64002 1095	25,0	64005 1250	9,7	64203 1097	27,7	64203 1277	13,2	64214 1132
10,0	64002 1100	25,5	64005 1255	10,2	64203 1102	28,2	64203 1282	13,7	64214 1137
10,5	64002 1105	26,0	64005 1260	10,7	64203 1107	28,7	64203 1287	14,2	64214 1142
11,0	64002 1110	26,5	64005 1265	11,2	64203 1112	29,2	64203 1292	14,7	64214 1147
11,5	64002 1115	27,0	64005 1270	11,7	64203 1117	29,7	64203 1297	15,2	64214 1152
12,0	64002 1120	27,5	64005 1275	12,2	64203 1122	30,2	64203 1302	15,7	64214 1157
12,5	64002 1125	28,0	64005 1280	12,7	64203 1127	30,7	64203 1307	16,2	64214 1162
13,0	64002 1130	28,5	64005 1285	13,2	64203 1132	31,2	64203 1312	16,7	64214 1167
13,5	64002 1135	29,0	64005 1290	13,7	64203 1137	31,7	64203 1317	17,2	64214 1172
14,0	64002 1140	29,5	64005 1295	14,2	64203 1142	32,2	64203 1322	17,7	64214 1177
14,5	64002 1145	30,0	64005 1300	14,7	64203 1147	32,7	64203 1327	18,2	64214 1182
15,0	64002 1150	30,5	64005 1305	15,2	64203 1152	33,2	64203 1332	18,7	64214 1187
15,5	64002 1155	31,0	64005 1310	15,7	64203 1157			19,2	64214 1192
16,0	64002 1160	31,5	64005 1315	16,2	64203 1162			19,7	64214 1197
16,5	64002 1165	32,0	64005 1320	16,7	64203 1167			20,2	64214 1202
17,0	64002 1170			17,2	64203 1172			20,7	64214 1207
17,5	64002 1175			17,7	64203 1177			21,2	64214 1212
18,0	64002 1180			18,2	64203 1182			21,7	64214 1217
18,5	64002 1185			18,7	64203 1187			22,2	64214 1222
19,0	64002 1190			19,2	64203 1192			22,7	64214 1227
				19,7	64203 1197			23,2	64214 1232
								23,7	64214 1237
								24,2	64214 1242
								24,7	64214 1247



Reduzierhülse 2 / 5
 reducing sleeve
 réducteur



44081 198 503

Schneidspiel: Seite
 clearance: see page
 jeu: voir page
 71



Streichmaß: Seite
 back marks: see page
 trusquinage: voir page
 73

Grüne Serie • Green Series • Série verte

Vierkantstempel
square punch
poignon carré

Vierkantmatrize
square die
matrice carrée

Langlochstempel
oblong punch
poignon oblong

Langlochmatrize
oblong die
matrice oblongue

Nr. 2

Nr. 3

Nr. 2

Nr. 3

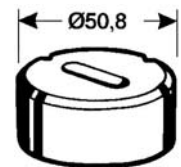
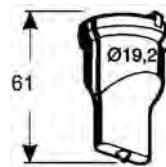
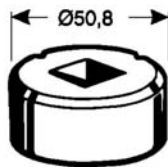
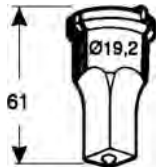

Vierkantstempel		Vierkantmatrize		Langlochstempel		Langlochmatrize	
square punch		square die		oblong punch		oblong die	
poignon carré		matrice carrée		poignon oblong		matrice oblongue	
Nr. 2		Nr. 3		Nr. 2		Nr. 3	
	Artikel-Nr.		Artikel-Nr.		Artikel-Nr.		Artikel-Nr.
4,0	64002 2040	4,2	64203 2042	5,0 × 10,0	64002 3 050100	5,2 × 10,2	64203 3 052102
5,0	64002 2050	5,2	64203 2052			5,7 × 10,7	64203 3 057107
6,0	64002 2060	6,2	64203 2062	5,0 × 14,0	64002 3 050140	5,2 × 14,2	64203 3 052142
7,0	64002 2070	6,7	64203 2067			5,7 × 14,7	64203 3 057147
8,0	64002 2080	7,2	64203 2072	5,5 × 10,0	64002 3 055100	5,7 × 10,2	64203 3 057102
9,0	64002 2090	7,7	64203 2077			6,2 × 10,7	64203 3 062107
10,0	64002 2100	8,2	64203 2082	5,5 × 14,0	64002 3 055140	5,7 × 14,2	64203 3 057142
11,0	64002 2110	8,7	64203 2087			6,2 × 14,7	64203 3 062147
12,0	64002 2120	9,2	64203 2092	5,5 × 19,0	64002 3 055190	5,7 × 19,2	64203 3 057192
13,0	64002 2130	9,7	64203 2097			6,2 × 19,7	64203 3 062197
		10,2	64203 2102	6,5 × 12,0	64002 3 065120	6,7 × 12,2	64203 3 067122
		10,7	64203 2107			7,2 × 12,7	64203 3 072127
		11,2	64203 2112	6,5 × 18,0	64002 3 065180	6,7 × 18,2	64203 3 067182
		11,7	64203 2117			7,2 × 18,7	64203 3 072187
		12,2	64203 2122	7,5 × 14,0	64002 3 075140	7,7 × 14,2	64203 3 077142
		12,7	64203 2127			8,2 × 14,7	64203 3 082147
		13,2	64203 2132	9,0 × 14,0	64002 3 090140	9,2 × 14,2	64203 3 092142
		13,7	64203 2137			9,7 × 14,7	64203 3 097147
		14,2	64203 2142	9,0 × 18,0	64002 3 090180	9,2 × 18,2	64203 3 092182
		14,7	64203 2147			9,7 × 18,7	64203 3 097187
		15,2	64203 2152	10,0 × 14,0	64002 3 100140	10,2 × 14,2	64203 3 102142
		15,7	64203 2157			10,7 × 14,7	64203 3 107147
		16,2	64203 2162			11,2 × 15,2	64203 3 112152
		16,7	64203 2167				
		17,2	64203 2172				
		17,7	64203 2177				
		18,2	64203 2182				
		18,7	64203 2187				
		19,2	64203 2192				
		19,7	64203 2197				
		20,2	64203 2202				
		20,7	64203 2207				
		21,2	64203 2212				
		21,7	64203 2217				
		22,2	64203 2222				
		22,7	64203 2227				
		23,2	64203 2232				
		23,7	64203 2237				

Vierkantstempel
square punch
poignon carré

Nr. 5

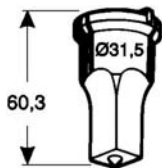

Vierkantstempel	
square punch	
poignon carré	
Nr. 5	
	Artikel-Nr.
14,0	64005 2140
15,0	64005 2150
16,0	64005 2160
17,0	64005 2170
18,0	64005 2180
19,0	64005 2190
20,0	64005 2200
21,0	64005 2210
22,0	64005 2220

Materialdicke	Schneidspiel	siehe Seite
material thickness	clearance	see page
épaisseur du matériau	jeu	voir page
bis 4 mm	0,2 mm	
4 – 9 mm	0,7 mm	71
9 – 14 mm	1,2 mm	

Grüne Serie • Green Series • Série verte

Langlochstempel
 oblong punch
 poinçon oblong

Langlochmatrize
 oblong die
 matrice oblongue

Langlochstempel
 oblong punch
 poinçon oblong

Langlochmatrize
 oblong die
 matrice oblongue

Nr. 5

Nr. 3

Nr. 5

Nr. 3

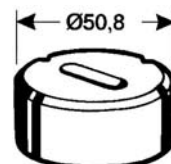
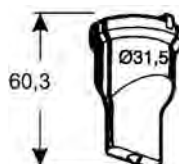
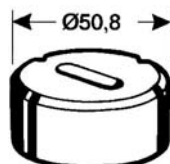
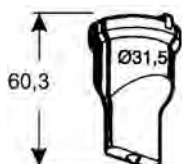

	Artikel-Nr.		Artikel-Nr.		Artikel-Nr.		Artikel-Nr.
5,5 × 25,0	64005 3 055250	5,7 × 25,2	64203 3 057252	12,0 × 24,0	64005 3 120240	12,2 × 24,2	64203 3 122242
		6,2 × 25,7	64203 3 062257			12,7 × 24,7	64203 3 127247
6,5 × 26,0	64005 3 065260	6,7 × 26,2	64203 3 067262	12,0 × 30,0	64005 3 120300	13,2 × 25,2	64203 3 132252
		7,2 × 26,7	64203 3 072267			12,2 × 30,2	64203 3 122302
6,5 × 30,0	64005 3 065300	6,7 × 30,2	64203 3 067302			12,7 × 30,7	64203 3 127307
		7,2 × 30,7	64203 3 072307	13,0 × 26,0	64005 3 130260	13,2 × 31,2	64203 3 132312
7,5 × 21,0	64005 3 075210	7,7 × 21,2	64203 3 077212			13,2 × 26,2	64203 3 132262
		8,2 × 21,7	64203 3 082217	13,0 × 30,0	64005 3 130300	13,7 × 26,7	64203 3 137267
7,5 × 26,0	64005 3 075260	7,7 × 26,2	64203 3 077262			14,2 × 27,2	64203 3 142272
		8,2 × 26,7	64203 3 082267	13,0 × 26,0	64005 3 130260	13,2 × 30,2	64203 3 132302
7,5 × 30,0	64005 3 075300	7,7 × 30,2	64203 3 077302			13,7 × 30,7	64203 3 137307
		8,2 × 30,7	64203 3 082307	14,0 × 26,0	64005 3 140260	14,2 × 31,2	64203 3 142312
9,0 × 26,0	64005 3 090260	9,2 × 26,2	64203 3 092262			14,2 × 26,2	64203 3 142262
		9,7 × 26,7	64203 3 097267	14,0 × 28,0	64005 3 140280	14,7 × 26,7	64203 3 147267
9,0 × 30,0	64005 3 090300	9,2 × 30,2	64203 3 092302			15,2 × 27,2	64203 3 152272
		9,7 × 30,7	64203 3 097307	16,0 × 26,0	64005 3 160260	14,2 × 28,2	64203 3 142282
10,0 × 20,0	64005 3 100200	10,2 × 20,2	64203 3 102202			14,7 × 28,7	64203 3 147287
		10,7 × 20,7	64203 3 107207	16,0 × 26,0	64005 3 160260	15,2 × 29,2	64203 3 152292
10,0 × 26,0	64005 3 100260	11,2 × 21,2	64203 3 112212			16,2 × 26,2	64203 3 162262
		10,2 × 26,2	64203 3 102262	16,0 × 31,0	64005 3 160310	16,7 × 26,7	64203 3 167267
10,0 × 30,0	64005 3 100300	10,7 × 26,7	64203 3 107267			17,2 × 27,2	64203 3 172272
		11,2 × 27,2	64203 3 112272	18,0 × 26,0	64005 3 180260	16,2 × 31,2	64203 3 162312
11,0 × 22,0	64005 3 110220	10,2 × 30,2	64203 3 102302			16,7 × 31,7	64203 3 167317
		10,7 × 30,7	64203 3 107307	18,0 × 31,0	64005 3 180310	17,2 × 32,2	64203 3 172322
11,0 × 26,0	64005 3 110260	11,2 × 31,2	64203 3 112312			18,2 × 26,2	64203 3 182262
		11,2 × 22,2	64203 3 112222	18,0 × 26,0	64005 3 180260	18,7 × 26,7	64203 3 187267
11,0 × 30,0	64005 3 110300	11,7 × 22,7	64203 3 117227			19,2 × 27,2	64203 3 192272
		12,2 × 23,2	64203 3 122232	18,0 × 31,0	64005 3 180310	18,2 × 31,2	64203 3 182312
11,0 × 26,0	64005 3 110260	11,2 × 26,2	64203 3 112262			18,7 × 31,7	64203 3 187317
		11,7 × 26,7	64203 3 117267	20,0 × 31,0	64005 3 200310	19,2 × 32,2	64203 3 192322
11,0 × 30,0	64005 3 110300	12,2 × 27,2	64203 3 122272			20,2 × 31,2	64203 3 202312
		11,2 × 30,2	64203 3 112302	22,0 × 31,0	64005 3 220310	20,7 × 31,7	64203 3 207317
		11,7 × 30,7	64203 3 117307			21,2 × 32,2	64203 3 212322
		12,2 × 31,2	64203 3 122312			22,2 × 31,2	64203 3 222312
						22,7 × 31,7	64203 3 227317
						23,2 × 32,2	64203 3 232322

Schneidpiel / clearance / jeu: **0,2 mm** (bis 4 mm Materialdicke) • **0,7 mm** (4 – 9 mm Materialdicke) • **1,2 mm** (9 – 14 mm Materialdicke)



Peddinghaus

Peddinghaus Anlagen & Maschinen GmbH

Peddinghaus Anlagen & Maschinen GmbH
Hasslinghauser Str. 156 • D-58285 Gevelsberg
Tel. +49 (0) 2332 / 6646-21/22/23
Fax +49 (0) 2332 / 6646-46
teile-pam@peddy.de • www.peddy.de

Grüne Serie • Green Series • Série verte

Langlochstempel
oblong punch
poinçon oblong

Langlochstempel
oblong punch
poinçon oblong

**Langloch-
Winkelstahlmatrize, längs**
oblong offset die, longitudinal
matrice oblongue décentrée,
sens longitudinal

**Langloch-
Winkelstahlmatrize, quer**
oblong offset die, transverse
matrice oblongue décentrée,
sens transversal

Nr. 2

Nr. 5

Nr. 14

Nr. 14

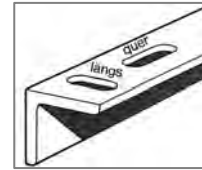
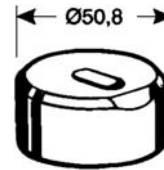
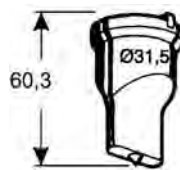
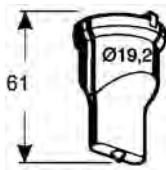

	Artikel-Nr.		Artikel-Nr.		Artikel-Nr.		Artikel-Nr.
5,5 × 14,0	64002 3 055140			6,2 × 14,7	64214 3 062147	6,2 × 14,7	64214 4 062147
		5,5 × 25,0	64005 3 055250	6,2 × 25,7	64214 3 062257	6,2 × 25,7	64214 4 062257
		6,5 × 26,0	64005 3 065260	7,2 × 26,7	64214 3 072267	7,2 × 26,7	64214 4 072267
		7,5 × 26,0	64005 3 075260	8,2 × 26,7	64214 3 082267	8,2 × 26,7	64214 4 082267
9,0 × 14,0	64002 3 090140			9,7 × 14,7	64214 3 097147	9,7 × 14,7	64214 4 097147
		9,0 × 26,0	64005 3 090260	9,7 × 26,7	64214 3 097267	9,7 × 26,7	64214 4 097267
		10,0 × 20,0	64005 3 100200	10,7 × 20,7	64214 3 107207	10,7 × 20,7	64214 4 107207
		11,0 × 22,0	64005 3 110220	11,7 × 22,7	64214 3 117227	11,7 × 22,7	64214 4 117227
		11,0 × 26,0	64005 3 110260	11,7 × 26,7	64214 3 117267	11,7 × 26,7	64214 4 117267
		13,0 × 26,0	64005 3 130260	13,7 × 26,7	64214 3 137267	13,7 × 26,7	64214 4 137267
		14,0 × 26,0	64005 3 140260	14,7 × 26,7	64214 3 147267	14,7 × 26,7	64214 4 147267
		16,0 × 26,0	64005 3 160260	16,7 × 26,7	64214 3 167267	16,7 × 26,7	64214 4 167267

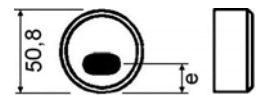

Streichmaß bei Exzentermatrizen
back marks on offset dies
trusquinage, matrices décentrées

siehe Seite
see page
voir page
73

Grüne Serie • Green Series • Série verte

Rechteckstempel
 rectangular punch
 poinçon rectangulaire

Rechteckmatrize
 rectangular die
 matrice rectangulaire

Schlüssellochstempel*
 key hole punch*
 poinçon pour canon européen*

Schlüssellochmatrize
 key hole die
 matrice pour canon européen

Nr. 5

Nr. 3

Nr. 5

Nr. 3

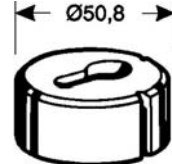
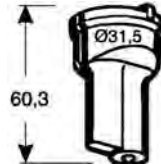
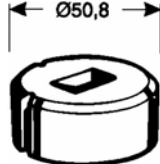
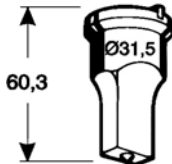

	Artikel-Nr.
5,0 × 15	64005 5 050150
5,0 × 20	64005 5 050200
6,0 × 24	64005 5 060240
8,0 × 16	64005 5 080160
8,0 × 24	64005 5 080240
9,0 × 24	64005 5 090240
10,0 × 20	64005 5 100200
11,0 × 22	64005 5 110220
12,0 × 22	64005 5 120220
12,0 × 30	64005 5 120300
14,0 × 20	64005 5 140200
16,0 × 20	64005 5 160200

	Artikel-Nr.
5,2 × 15,2	64203 5 052152
5,7 × 15,7	64203 5 057157
5,2 × 20,2	64203 5 052202
5,7 × 20,7	64203 5 057207
6,2 × 24,2	64203 5 062242
6,7 × 24,7	64203 5 067247
8,2 × 16,2	64203 5 082162
8,7 × 16,7	64203 5 087167
8,2 × 24,2	64203 5 082242
8,7 × 24,7	64203 5 087247
9,2 × 24,2	64203 5 092242
9,7 × 24,7	64203 5 097247
10,2 × 20,2	64203 5 102202
10,7 × 20,7	64203 5 107207
11,2 × 22,2	64203 5 112222
11,7 × 22,7	64203 5 117227
12,2 × 22,2	64203 5 122222
12,7 × 22,7	64203 5 127227
12,2 × 30,2	64203 5 122302
12,7 × 30,7	64203 5 127307
14,2 × 20,2	64203 5 142202
14,7 × 20,7	64203 5 147207
16,2 × 20,2	64203 5 162202
16,7 × 20,7	64203 5 167207

	Artikel-Nr.
34,0 × Ø17,5 × 10,5	65005 17001

*zusätzlich erforderlich :
 *additionally required • nécessaire en plus:

für Stempel-Schnellwechsellvorrichtung
 – grüne Serie – ab 1993
 for quick-change punching attachments
 – green series – supplied since 1993
 pour dispositifs de serrage rapide,
 – série verte – fournis depuis 1993

Schnellspanneinsatz Schlüsselloch
 quick-change punch sleeve, keyhole
 douille de serrage rapide, canon européen

vor • prior to • avant • 1993:
Schnellspanneinsatz Schlüsselloch
 quick-change punch sleeve, keyhole
 douille de serrage rapide, canon européen

	Artikel-Nr.
34,2 × Ø17,7 × 10,7	65203 17001

42217 620 02 02

P-44081 620 05 01

Eckenabrundstempel
 corner radiusing punch
 poinçon p. arrondir les angles

Eckenabrundmatrize
 corner radiusing die
 matrice p. arrondir les angles

Drehriegelstempel
 hasp hole punch
 poinçon trou d'espagnolette

Drehriegelmatrize
 hasp hole die
 matrice trou d'espagnolette

Nr. 5

Nr. 3

Nr. 5

Nr. 3

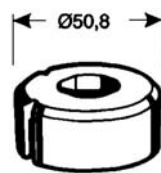
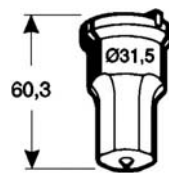
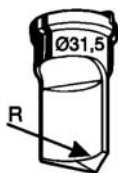

Radius	Artikel-Nr.
5	65005 37 00050
10	65005 37 00100
15	65005 37 00150

Radius	Artikel-Nr.
5	65203 37 00050
10	65203 37 00100
14	65203 37 00140
15	65203 37 00150

	Artikel-Nr.
Ø 22,2 × 20,3	65005 38 222203

	Artikel-Nr.
Ø 22,4 × 20,5	65203 38 224205

Grüne Serie • Green Series • Série verte

Spezial-Stempel zum Stanzen von VA-Material Special Punches for Punching Stainless Steel Poinçons spéciaux pour poinçonner du matériau inox

Spezial-Rundstempel
special round punch
poinçon rond spécial

Rundmatrize (Standard)
 round die (standard)
 matrice ronde (standard)

Rundmatrize (Standard)
 round die (standard)
 matrice ronde (standard)

Spezial-Vierkantstempel
special square punch
poinçon carré spécial

Nr. 2

Nr. 3

Nr. 3

Nr. 2

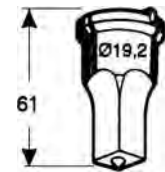
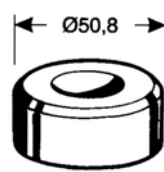
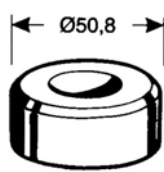
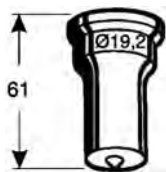

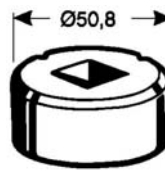
Artikel-Nr.	Artikel-Nr.	Artikel-Nr.	Artikel-Nr.
3,0 P-65002 8012 030	3,2 64203 1032	12,2 64203 1122	9,0 P-65002 8014 090 Vierkantmatrize (Standard) square die (standard) matrice carrée (standard)
4,0 P-65002 8012 040	3,7 64203 1037	12,7 64203 1127	
4,5 P-65002 8012 045	4,2 64203 1042	13,2 64203 1132	
5,0 P-65002 8012 050	4,7 64203 1047	13,7 64203 1137	
5,5 P-65002 8012 055	5,2 64203 1052	14,2 64203 1142	
6,0 P-65002 8012 060	5,7 64203 1057	14,7 64203 1147	
6,5 P-65002 8012 065	6,2 64203 1062	15,2 64203 1152	
7,0 P-65002 8012 070	6,7 64203 1067	15,7 64203 1157	
8,0 P-65002 8012 080	7,2 64203 1072	16,2 64203 1162	
9,0 P-65002 8012 090	7,7 64203 1077	16,7 64203 1167	
10,0 P-65002 8012 100	8,2 64203 1082	17,2 64203 1172	
11,0 P-65002 8012 110	8,7 64203 1087	17,7 64203 1177	
12,0 P-65002 8012 120	9,2 64203 1092	18,2 64203 1182	
13,0 P-65002 8012 130	9,7 64203 1097		
14,0 P-65002 8012 140	10,2 64203 1102		
15,0 P-65002 8012 150	10,7 64203 1107		
16,0 P-65002 8012 160	11,2 64203 1112		
17,0 P-65002 8012 170	11,7 64203 1117		
			Nr. 3
			
			Artikel-Nr.
			9,7 64203 2097

Spezial-Langlochstempel
special oblong punch
poinçon oblong spécial

Langlochmatrize (Standard)
 oblong die (standard)
 matrice oblongue (standard)

Spezial-Langlochstempel
special oblong punch
poinçon oblong spécial

Langlochmatrize (Standard)
 oblong die (standard)
 matrice oblongue (standard)

Nr. 2

Nr. 3

Nr. 5

Nr. 3

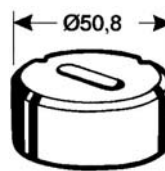
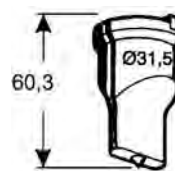
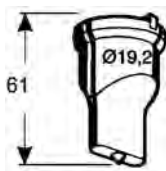

Artikel-Nr.	Artikel-Nr.	Artikel-Nr.	Artikel-Nr.
9,0 × 14,0 P-65002 8013 01	9,7 × 14,7 64203 3 097147	10,0 × 30,0 P-65005 8024 01	10,7 × 30,7 64203 3 107307
9,0 × 18,0 P-65002 8013 03	9,7 × 18,7 64203 3 097187		11,2 × 31,2 64203 3 112312
		11,0 × 26,0 P-65005 8024 04	11,7 × 26,7 64203 3 117267
			12,2 × 27,2 64203 3 122272
		11,0 × 30,0 P-65005 8024 03	11,7 × 30,7 64203 3 117307
			12,2 × 31,2 64203 3 122312

Rote Serie • Red Series • Série rouge

für ältere Modelle:
for older machine types:
pour modèles plus anciens:

Peddicat 360
Peddiworker 400 • 500 • 600 • 800
Peddimaster 450M • 28/40 • 40/60 • 60/80 • 60/100 • 80/110
Hydraulic 40 • 60N • 300 • 500 • 600
210 Super 11 • 13, 210 Standard 11 • 13
Forax 15 • 25 • 45 • 65 • 150 • 250 • 450
Stanzfix
225 B/11 • 13 • 45 • 60
225 H/11 • 13

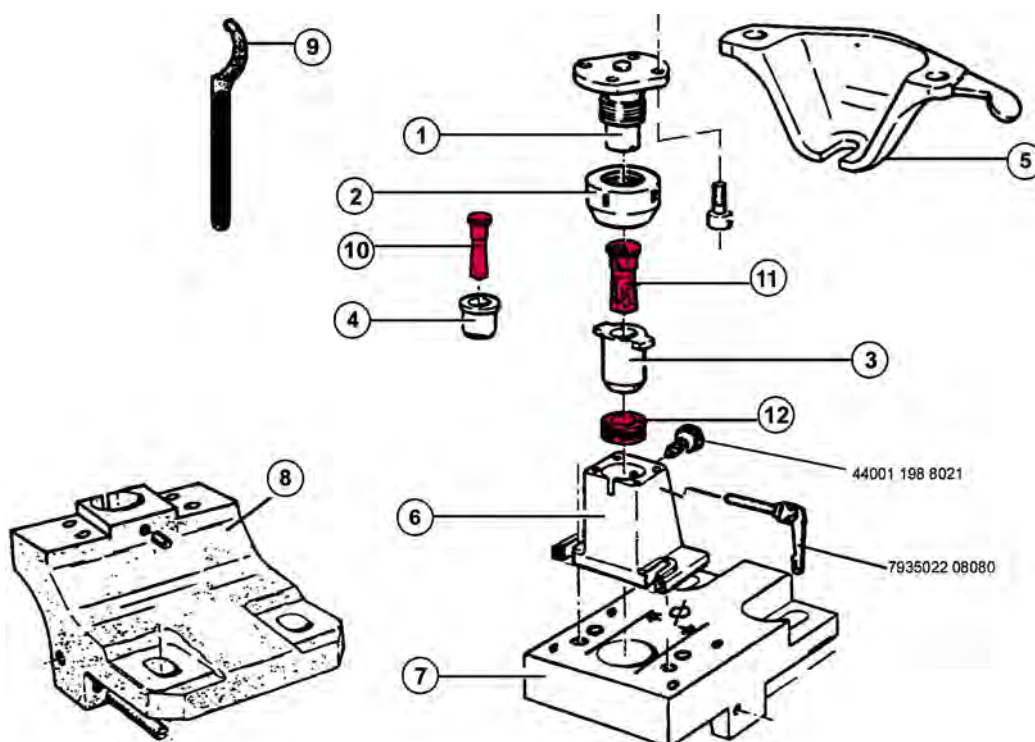

Stempel und Matrizen zur Schnellwechsellvorrichtung
Punches and dies for the quick-change punching attachment
Poinçons et matrices pour utilisation dans le dispositif de serrage rapide du poinçon



Peddinghaus

Peddinghaus Anlagen & Maschinen GmbH

Peddinghaus Anlagen & Maschinen GmbH
Hasslinghauser Str. 156 • D-58285 Gevelsberg
Tel. +49 (0) 2332 / 6646-21/22/23
Fax +49 (0) 2332 / 6646-46
teile-pam@peddy.de • www.peddy.de

Rote Serie • Red Series • Série rouge

Rundstempel
round punch
poinçon rond

Rundstempel
round punch
poinçon rond

Rundmatrize
round die
matrice ronde

Rundmatrize
round die
matrice ronde

Winkelstahlmatrize
offset flat die
matrice ronde décentrée

Nr. 1

Nr. 4

Nr. 2

Nr. 2

Nr. 13

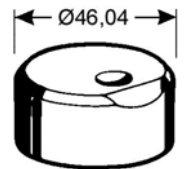
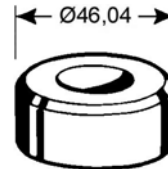
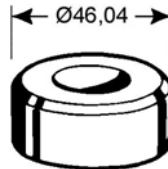
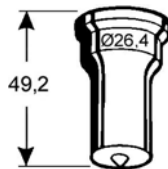
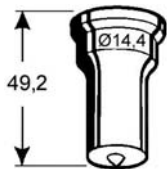

Artikel-Nr.	Artikel-Nr.	Artikel-Nr.	Artikel-Nr.	Artikel-Nr.
3,0 64001 1030	8,0 64004 1080	3,2 64202 1032	19,2 64202 1192	5,2 64213 1052
3,2 64001 1032	8,5 64004 1085	3,4 64202 1034	19,7 64202 1197	5,7 64213 1057
3,5 64001 1035	9,0 64004 1090	3,7 64202 1037	20,2 64202 1202	6,2 64213 1062
4,0 64001 1040	9,5 64004 1095	4,2 64202 1042	20,7 64202 1207	6,7 64213 1067
4,2 64001 1042	10,0 64004 1100	4,4 64202 1044	21,2 64202 1212	7,2 64213 1072
4,5 64001 1045	10,5 64004 1105	4,7 64202 1047	21,7 64202 1217	7,7 64213 1077
5,0 64001 1050	11,0 64004 1110	5,2 64202 1052	22,2 64202 1222	8,2 64213 1082
5,5 64001 1055	11,5 64004 1115	5,7 64202 1057	22,7 64202 1227	8,7 64213 1087
6,0 64001 1060	12,0 64004 1120	6,2 64202 1062	23,2 64202 1232	9,2 64213 1092
6,5 64001 1065	12,5 64004 1125	6,7 64202 1067	23,7 64202 1237	9,7 64213 1097
7,0 64001 1070	13,0 64004 1130	7,2 64202 1072	24,2 64202 1242	10,2 64213 1102
7,5 64001 1075	13,5 64004 1135	7,7 64202 1077	24,7 64202 1247	10,7 64213 1107
8,0 64001 1080	14,0 64004 1140	8,2 64202 1082	25,2 64202 1252	11,2 64213 1112
8,5 64001 1085	14,5 64004 1145	8,7 64202 1087	25,7 64202 1257	11,7 64213 1117
9,0 64001 1090	15,0 64004 1150	9,2 64202 1092	26,2 64202 1262	12,2 64213 1122
9,5 64001 1095	15,5 64004 1155	9,7 64202 1097	26,7 64202 1267	12,7 64213 1127
10,0 64001 1100	16,0 64004 1160	10,2 64202 1102	27,2 64202 1272	13,2 64213 1132
10,5 64001 1105	16,5 64004 1165	10,7 64202 1107	27,7 64202 1277	13,7 64213 1137
11,0 64001 1110	17,0 64004 1170	11,2 64202 1112	28,2 64202 1282	14,2 64213 1142
11,5 64001 1115	17,5 64004 1175	11,7 64202 1117	28,7 64202 1287	14,7 64213 1147
12,0 64001 1120	18,0 64004 1180	12,2 64202 1122	29,2 64202 1292	15,2 64213 1152
12,5 64001 1125	18,5 64004 1185	12,7 64202 1127	29,7 64202 1297	15,7 64213 1157
13,0 64001 1130	19,0 64004 1190	13,2 64202 1132	30,2 64202 1302	16,2 64213 1162
13,5 64001 1135	19,5 64004 1195	13,7 64202 1137	30,7 64202 1307	16,7 64213 1167
14,0 64001 1140	20,0 64004 1200	14,2 64202 1142		17,2 64213 1172
	20,5 64004 1205	14,7 64202 1147		17,7 64213 1177
	21,0 64004 1210	15,2 64202 1152		18,2 64213 1182
	21,5 64004 1215	15,7 64202 1157		18,7 64213 1187
	22,0 64004 1220	16,2 64202 1162		19,2 64213 1192
	22,5 64004 1225	16,7 64202 1167		19,7 64213 1197
	23,0 64004 1230	17,2 64202 1172		20,2 64213 1202
	23,5 64004 1235	17,7 64202 1177		20,7 64213 1207
	24,0 64004 1240	18,2 64202 1182		21,2 64213 1212
	24,5 64004 1245	18,7 64202 1187		21,7 64213 1217
	25,0 64004 1250		Schneidspiel: Seite clearance: see page jeu: voir page 71	22,2 64213 1222
	25,5 64004 1255			22,7 64213 1227
	26,0 64004 1260			
	26,5 64004 1265			
	27,0 64004 1270			



Reduzierhülse 1/4
reducing sleeve
réducteur



44001 198 503

Stempel-Übergröße:
oversize punch:
poinçon surdimension:

28,0 64004 1280
29,0 64004 1290
30,0 64004 1300

zusätzlich erforderlich:
additionally required:
nécessaire en plus:

Spezial-Schnellspanneinsatz
special quick-change punch sleeve
douille de serrage rapide spéciale
44001 6 3523 01



Streichmaß: Seite
back marks: see page
trusquinage: voir page
73

Rote Serie • Red Series • Série rouge

Vierkantstempel
square punch
poignon carré

Vierkantmatrize
square die
matrice carrée

Langlochstempel
oblong punch
poignon oblong

Langlochmatrize
oblong die
matrice oblongue

Nr. 1

Nr. 2

Nr. 1

Nr. 2

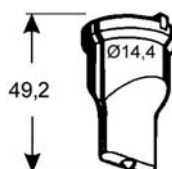
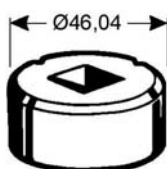
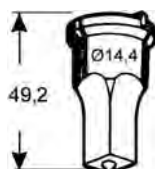

	Artikel-Nr.
4,0	64001 2040
5,0	64001 2050
6,0	64001 2060
7,0	64001 2070
8,0	64001 2080
9,0	64001 2090
10,0	64001 2100
Vierkantstempel square punch poignon carré	
Nr. 4	
	Artikel-Nr.
11,0	64004 2110
12,0	64004 2120
13,0	64004 2130
14,0	64004 2140
15,0	64004 2150
16,0	64004 2160
17,0	64004 2170
18,0	64004 2180
19,0	64004 2190
20,0*	64004 2200
21,0*	64004 2210

	Artikel-Nr.
4,2	64202 2042
5,2	64202 2052
6,2	64202 2062
6,7	64202 2067
7,2	64202 2072
7,7	64202 2077
8,2	64202 2082
8,7	64202 2087
9,2	64202 2092
9,7	64202 2097
10,2	64202 2102
10,7	64202 2107
11,2	64202 2112
11,7	64202 2117
12,2	64202 2122
12,7	64202 2127
13,2	64202 2132
13,7	64202 2137
14,2	64202 2142
14,7	64202 2147
15,2	64202 2152
15,7	64202 2157
16,2	64202 2162
16,7	64202 2167
17,2	64202 2172
17,7	64202 2177
18,2	64202 2182
18,7	64202 2187
19,2	64202 2192
19,7	64202 2197
20,2	64202 2202
20,7	64202 2207
21,2	64202 2212
21,7	64202 2217

	Artikel-Nr.
5,0 × 10	64001 3050100
5,0 × 14	64001 3050140
5,5 × 10	64001 3055100
5,5 × 14	64001 3055140
6,5 × 12	64001 3065120
7,5 × 14	64001 3075140
9,0 × 14	64001 3090140
10,0 × 14	64001 3100140

	Artikel-Nr.
5,2 × 10,2	64202 3 052102
5,7 × 10,7	64202 3 057107
5,2 × 14,2	64202 3 052142
5,7 × 14,7	64202 3 057147
5,7 × 10,2	64202 3 057102
6,2 × 10,7	64202 3 062107
5,7 × 14,2	64202 3 057142
6,2 × 14,7	64202 3 062147
6,7 × 12,2	64202 3 067122
7,2 × 12,7	64202 3 072127
7,7 × 14,2	64202 3 077142
8,2 × 14,7	64202 3 082147
9,2 × 14,2	64202 3 092142
9,7 × 14,7	64202 3 097147
10,2 × 14,2	64202 3 102142
10,7 × 14,7	64202 3 107147

* Übergröße,
zusätzlich erforderlich:
* oversize,
additionally required:
* surdimension,
nécessaire en plus :



65004 8087 01

Spezial-Schnellspanneinsatz
special quick-change punch sleeve
douille de serrage rapide spéciale

Materialdicke material thickness épaisseur du matériau bis 4 mm	Schneidspiel clearance jeu	siehe Seite see page voir page
4 – 9 mm	0,2 mm	
9 – 14 mm	0,7 mm	71
	1,2 mm	



Peddinghaus

Peddinghaus Anlagen & Maschinen GmbH

Peddinghaus Anlagen & Maschinen GmbH
 Hasslinghauser Str. 156 • D-58285 Gevelsberg
 Tel. +49 (0) 2332 / 6646-21/22/23
 Fax +49 (0) 2332 / 6646-46
 teile-pam@peddy.de • www.peddy.de

Rote Serie • Red Series • Série rouge

Langlochstempel
 oblong punch
 poinçon oblong

Langlochmatrize
 oblong die
 matrice oblongue

**Langloch-
 Winkelstahlmatrize, längs**
 oblong offset die, longitudinal
 matrice oblongue décentrée,
 sens longitudinal

**Langloch-
 Winkelstahlmatrize, quer**
 oblong offset die, transverse
 matrice oblongue décentrée,
 sens transversal

Nr. 4

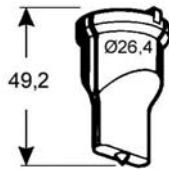

Nr. 2



Nr. 13

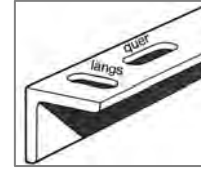
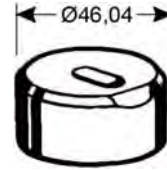

Nr. 13



Artikel-Nr.	Artikel-Nr.	Artikel-Nr.	Artikel-Nr.
5,5 × 19 64004 3055190	5,7 × 19,2 64202 3 057192	6,2 × 14,7 64213 3 062147 9,7 × 14,7 64213 3 097147	6,2 × 14,7 64213 4 062147 9,7 × 14,7 64213 4 097147
5,5 × 25 64004 3055250	6,2 × 19,7 64202 3 062197		
6,5 × 18 64004 3065180	5,7 × 25,2 64202 3 057252	6,2 × 25,7 64213 3 062257	6,2 × 25,7 64213 4 062257
6,5 × 26 64004 3065260	6,2 × 25,7 64202 3 062257		
7,5 × 21 64004 3075210	6,7 × 18,2 64202 3 067182	7,2 × 26,7 64213 3 072267	7,2 × 26,7 64213 4 072267
7,5 × 26 64004 3075260	7,2 × 18,7 64202 3 072187		
9,0 × 18 64004 3090180	6,7 × 26,2 64202 3 067262	8,2 × 26,7 64213 3 082267	8,2 × 26,7 64213 4 082267
9,0 × 26 64004 3090260	7,2 × 26,7 64202 3 072267		
10,0 × 20 64004 3100200	7,7 × 21,2 64202 3 077212	9,7 × 26,7 64213 3 097267	9,7 × 26,7 64213 4 097267
10,0 × 26 64004 3100260	7,7 × 21,2 64202 3 077212		
11,0 × 22 64004 3110220	8,2 × 21,7 64202 3 082217	10,7 × 20,7 64213 3 107207	10,7 × 20,7 64213 4 107207
11,0 × 26 64004 3110260	7,7 × 26,2 64202 3 077262		
12,0 × 24 64004 3120240	8,2 × 26,7 64202 3 082267	11,7 × 22,7 64213 3 117227	11,7 × 22,7 64213 4 117227
13,0 × 26 64004 3130260	9,2 × 18,2 64202 3 092182	11,7 × 26,7 64213 3 117267	11,7 × 26,7 64213 4 117267
14,0 × 26 64004 3140260	9,7 × 18,7 64202 3 097187		
16,0 × 26 64004 3160260	9,2 × 26,2 64202 3 092262	13,7 × 26,7 64213 3 137267	13,7 × 26,7 64213 4 137267
18,0 × 26 64004 3180260	9,7 × 26,7 64202 3 097267	14,7 × 26,7 64213 3 147267	14,7 × 26,7 64213 4 147267
	10,2 × 20,2 64202 3 102202		
	10,7 × 20,7 64202 3 107207	16,7 × 26,7 64213 3 167267	16,7 × 26,7 64213 4 167267
	10,2 × 26,2 64202 3 102262		
	10,7 × 26,7 64202 3 107267		
	11,2 × 22,2 64202 3 112222		
	11,7 × 22,7 64202 3 117227		
	11,2 × 26,2 64202 3 112262		
	11,7 × 26,7 64202 3 117267		
	12,2 × 24,2 64202 3 122242		
	12,7 × 24,7 64202 3 127247		
	13,2 × 26,2 64202 3 132262		
	13,7 × 26,7 64202 3 137267		
	14,2 × 26,2 64202 3 142262		
	14,7 × 26,7 64202 3 147267		
	16,2 × 26,2 64202 3 162262		
	16,7 × 26,7 64202 3 167267		
	18,2 × 26,2 64202 3 182262		
	18,7 × 26,7 64202 3 187267		



Streichmaß bei Exzentermatrizen
 back marks on offset dies
 trusquinage, matrices décentrées

siehe Seite
 see page
 voir page
 73

Rote Serie • Red Series • Série rouge

Rechteckstempel
 rectangular punch
 poinçon rectangulaire

Rechteckmatrize
 rectangular die
 matrice rectangulaire

Eckenabrundstempel
 corner radiusing punch
 poinçon pour arrondir les angles

Eckenabrundmatrize
 corner radiusing die
 matrice pour arrondir les angles

Nr. 4 Nr. 2 Nr. 4 Nr. 2

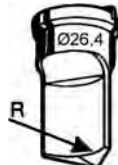
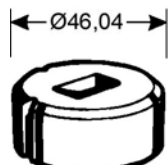
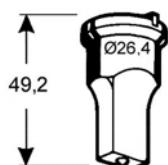

Nr. 4		Nr. 2		Nr. 4		Nr. 2	
Artikel-Nr.	Artikel-Nr.	Artikel-Nr.	Artikel-Nr.	Artikel-Nr.	Artikel-Nr.	Artikel-Nr.	Artikel-Nr.
5,0 × 15	64004 5 050150	5,2 × 15,2	64202 5 052152	Radius 5	65004 37 00050	Radius 5	65202 37 00050
		5,7 × 15,7	64202 5 057157	Radius 10	65004 37 00100	Radius 10	65202 37 00100
5,0 × 20	64004 5 050200	5,2 × 20,2	64202 5 052202	Radius 14	65004 37 00140	Radius 14	65202 37 00140
		5,7 × 20,7	64202 5 057207	Drehriegelstempel hasp hole punch poinçon trou d'espagnolette		Drehriegelmatrize hasp hole die matrice trou d'espagnolette	
6,0 × 24	64004 5 060240	6,2 × 24,2	64202 5 062242	Nr. 4		Nr. 2	
		6,7 × 24,7	64202 5 067247				
8,0 × 16	64004 5 080160	8,2 × 16,2	64202 5 082162	Artikel-Nr.		Artikel-Nr.	
		8,7 × 16,7	64202 5 087167	Ø 22,2 × 20,3 65004 38 222203		Ø 22,4 × 20,5 65202 38 224205	
8,0 × 24	64004 5 080240	8,2 × 24,2	64202 5 082242				
		8,7 × 24,7	64202 5 087247	Artikel-Nr.		Artikel-Nr.	
9,0 × 24	64004 5 090240	9,2 × 24,2	64202 5 092242	Ø 22,2		20,3	
		9,7 × 24,7	64202 5 097247				
10,0 × 20	64004 5 100200	10,2 × 20,2	64202 5 102202	20,3			
		10,7 × 20,7	64202 5 107207	Ø 22,2		20,3	
11,0 × 22	64004 5 110220	11,2 × 22,2	64202 5 112222	Ø 22,2		20,3	
		11,7 × 22,7	64202 5 117227	Ø 22,2		20,3	
12,0 × 22	64004 5 120220	12,2 × 22,2	64202 5 122222	Ø 22,2		20,3	
		12,7 × 22,7	64202 5 127227	Ø 22,2		20,3	
14,0 × 20	64004 5 140200	14,2 × 20,2	64202 5 142202	Ø 22,2		20,3	
		14,7 × 20,7	64202 5 147207	Ø 22,2		20,3	
16,0 × 20	64004 5 160200	16,2 × 20,2	64202 5 162202	Ø 22,2		20,3	
		16,7 × 20,7	64202 5 167207	Ø 22,2		20,3	

Materialdicke
 material thickness
 épaisseur du matériau
 bis 4 mm
 4 – 9 mm

Schneidspiel
 clearance
 jeu
 0,2 mm
 0,7 mm

siehe Seite
 see page
 voir page
 71

Rote Serie • Red Series • Série rouge

**Spezial-Stempel zum Stanzen von VA-Material
 Special Punches for Punching Stainless Steel
 Poinçons spéciaux pour poinçonner du matériau inox**

**Spezial-Rundstempel
 special round punch
 poinçon rond spécial**

Rundmatrize (Standard)
 round die (standard)
 matrice ronde (standard)

**Spezial-Langlochstempel
 special oblong punch
 poinçon oblong spécial**

Langlochmatrize (Standard)
 oblong die (standard)
 matrice oblongue (standard)

Nr. 1

Nr. 2

Nr. 4

Nr. 2

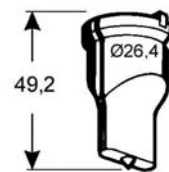
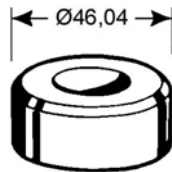
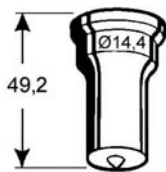

	Artikel-Nr.	Artikel-Nr.	Artikel-Nr.	Artikel-Nr.
3,0	P-65001 8004 030	3,2 64202 1032	9,0 × 26,0 P-65004 8008 01	9,7 × 26,7 64202 3 097267
4,0	P-65001 8004 040	3,7 64202 1037	11,0 × 26,0 P-65004 8008 02	11,7 × 26,7 64202 3 117267
4,5	P-65001 8004 045	4,2 64202 1042		12,2 × 27,2 64202 3 122272
5,0	P-65001 8004 050	4,7 64202 1047	13,0 × 26,0 P-65004 8008 03	13,7 × 26,7 64202 3 137267
6,0	P-65001 8004 060	5,2 64202 1052		14,2 × 27,2 64202 3 142272
7,0	P-65001 8004 070	5,7 64202 1057		
8,0	P-65001 8004 080	6,2 64202 1062		
9,0	P-65001 8004 090	6,7 64202 1067		
10,0	P-65001 8004 100	7,2 64202 1072		
11,0	P-65001 8004 110	7,7 64202 1077		
12,0	P-65001 8004 120	8,2 64202 1072		
13,0	P-65001 8004 130	8,7 64202 1077		
14,0	P-65001 8004 140	9,2 64202 1092		
		9,7 64202 1097		
		10,2 64202 1102		
		10,7 64202 1107		
		11,2 64202 1112		
		11,7 64202 1117		
		12,2 64202 1122		
		12,7 64202 1127		
		13,2 64202 1132		
		13,7 64202 1137		
		14,2 64202 1142		
		14,7 64202 1147		
		15,2 64202 1152		

Materialdicke	Schneidspiel	siehe Seite
material thickness	clearance	see page
épaisseur du matériau	jeu	voir page
bis 4 mm	0,2 mm	
4 – 9 mm	0,7 mm	71
9 – 14 mm	1,2 mm	

Blau Serie • Blue Series • Série bleue

für die Sonder-Stanzvorrichtungen bis 39 • 58 • 65 • 90 mm Ø
 suitable for the oversize punching attachments up to 39 • 58 • 65 • 90 mm Ø
 pour les dispositifs de poinçonnage grand diamètre jusqu'à 39 • 58 • 65 • 90 mm Ø

aller Modelle auf den Seiten 3 + 10
 of all models listed on pages 3 + 10
 de tous les modèles svt pages 3 + 10

für die Normal-Stanzvorrichtung der Modelle
 for the standard punching attachment of models
 pour le dispositif de poinçonnage standard des modèles

Peddimax No. 1 Hydraulic 1000 N
Hydraulic 1250 Hydraulic 1400 N

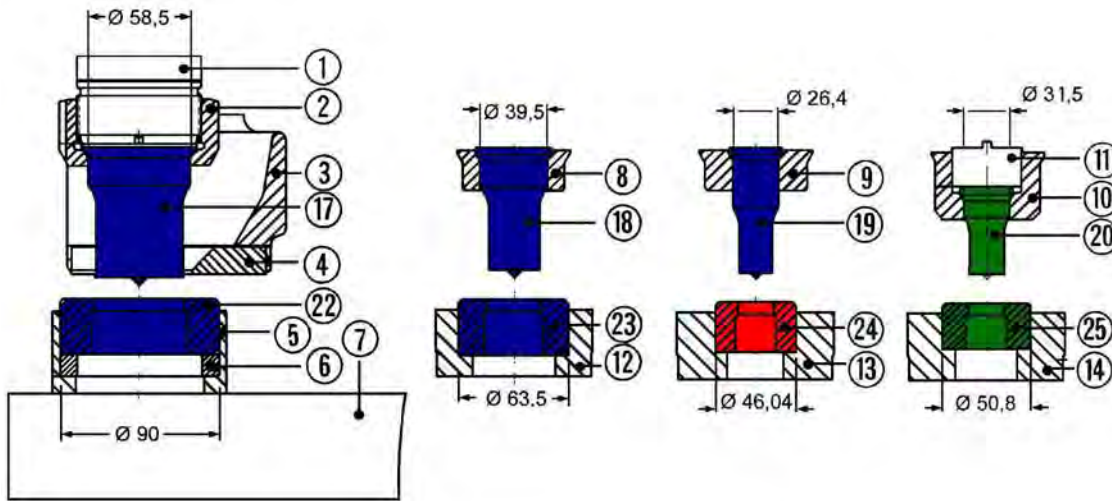

Sonder-Stanzvorrichtung bis 58 mm Ø komplett

mit Reduzierhülsen und Reduziereinsätzen für kleinere Stempel- bzw. Matrizenabmessungen

- 1 Stempelhalter
- 2 Stempelmutter
- 3 Abstreifer
- 4 .1 Abstreiferplatte Ø 15
- .2 Abstreiferplatte Ø 30
- .3 Abstreiferplatte Ø 40
- .4 Abstreiferplatte Ø 50
- .5 Abstreiferplatte Ø 60
- 5 Matrizenhalter
- 6 Auflagering
- 7 Stanzentisch
- 8 Reduzierhülse 6 / 7
- 9 Reduzierhülse 3 / 7
- 10 Verlängerungsreduzierhülse 5 / 7
- 11 Druckstück 5 / 7 + 11
- 12 Reduziereinsatz 4 / 6
- 13 Reduziereinsatz 2 / 6
- 14 Reduziereinsatz 3 / 6
- 17 Stempel Nr. 7
- 18 Stempel Nr. 6
- 19 Stempel Nr. 3
- 20 Stempel Nr. 5
- 22 Matrize Nr. 6
- 23 Matrize Nr. 4
- 24 Matrize Nr. 2
- 25 Matrize Nr. 3

Oversize punching attachment up to 58 mm Ø complete

including reducing sleeves and sockets for smaller size punches and dies

- punch holder
- locking nut
- stripper
- stripper plate Ø 15
- stripper plate Ø 30
- stripper plate Ø 40
- stripper plate Ø 50
- stripper plate Ø 60
- die holder
- die ring
- flat die bolster
- reducing sleeve 6 / 7
- reducing sleeve 3 / 7
- prolongation reducing sleeve 5 / 7
- filler piece 5 / 7 + 11
- reducing socket 4 / 6
- reducing socket 2 / 6
- reducing socket 3 / 6
- punch no. 7
- punch no. 6
- punch no. 3
- punch no. 5
- die no. 6
- die no. 4
- die no. 2
- die no. 3

Dispositif de poinçonnage grand diamètre jusqu'à 58 mm Ø, complet

avec réducteurs pour poinçons et matrices de taille plus petite

- porte-poinçon
- écrou de fixation
- dévêtisseur
- plaque de dévêtisseur Ø 15
- plaque de dévêtisseur Ø 30
- plaque de dévêtisseur Ø 40
- plaque de dévêtisseur Ø 50
- plaque de dévêtisseur Ø 60
- porte-matrice
- bague de support
- table de poinçonnage plate
- douille de réduction 6 / 7
- douille de réduction 3 / 7
- réducteur de rallonge 5 / 7
- rondelle de pression 5 / 7 + 11
- bague de réduction 4 / 6
- bague de réduction 2 / 6
- bague de réduction 3 / 6
- poinçon no. 7
- poinçon no. 6
- poinçon no. 3
- poinçon no. 5
- matrice no. 6
- matrice no. 4
- matrice no. 2
- matrice no. 3

Blau Serie • Blue Series • Série bleue

Rundstempel
 round punch
 poinçon rond

Rundstempel
 round punch
 poinçon rond

Rundmatrize
 round die
 matrice ronde

Rundmatrize
 round die
 matrice ronde

Nr. 3

Nr. 6

Nr. 4

Nr. 4

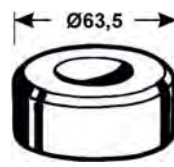
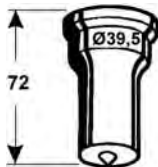
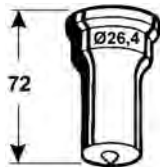

Ø	Artikel-Nr.	Ø	Artikel-Nr.	Ø	Artikel-Nr.	Ø	Artikel-Nr.
3,0	64003 1030	26,5	64006 1265	5,2	64204 1052	23,2	64204 1232
3,2	64003 1032	27,0	64006 1270	5,7	64204 1057	23,7	64204 1237
3,5	64003 1035	27,5	64006 1275	6,2	64204 1062	24,2	64204 1242
4,0	64003 1040	28,0	64006 1280	6,7	64204 1067	24,7	64204 1247
4,2	64003 1042	28,5	64006 1285	7,2	64204 1072	25,2	64204 1252
4,5	64003 1045	29,0	64006 1290	7,7	64204 1077	25,7	64204 1257
5,0	64003 1050	29,5	64006 1295	8,2	64204 1082	26,2	64204 1262
5,5	64003 1055	30,0	64006 1300	8,7	64204 1087	26,7	64204 1267
6,0	64003 1060	30,5	64006 1305	9,2	64204 1092	27,2	64204 1272
6,5	64003 1065	31,0	64006 1310	9,7	64204 1097	27,7	64204 1277
7,0	64003 1070	31,5	64006 1315	10,2	64204 1102	28,2	64204 1282
7,5	64003 1075	31,5	64006 1315	10,7	64204 1107	28,7	64204 1287
8,0	64003 1080	32,0	64006 1320	11,2	64204 1112	29,2	64204 1292
8,5	64003 1085	32,5	64006 1325	11,7	64204 1117	29,7	64204 1297
9,0	64003 1090	33,0	64006 1330	12,2	64204 1122	30,2	64204 1302
9,5	64003 1095	33,5	64006 1335	12,7	64204 1127	30,7	64204 1307
10,0	64003 1100	34,0	64006 1340	13,2	64204 1132	31,2	64204 1312
10,5	64003 1105	34,5	64006 1345	13,7	64204 1137	31,7	64204 1317
11,0	64003 1110	35,0	64006 1350	14,2	64204 1142	32,2	64204 1322
11,5	64003 1115	35,5	64006 1355	14,7	64204 1147	32,7	64204 1327
12,0	64003 1120	36,0	64006 1360	15,2	64204 1152	33,2	64204 1332
12,5	64003 1125	36,5	64006 1365	15,7	64204 1157	33,7	64204 1337
13,0	64003 1130	37,0	64006 1370	16,2	64204 1162	34,2	64204 1342
13,5	64003 1135	37,5	64006 1375	16,7	64204 1167	34,7	64204 1347
14,0	64003 1140	38,0	64006 1380	17,2	64204 1172	35,2	64204 1352
14,5	64003 1145	38,5	64006 1385	17,7	64204 1177	35,7	64204 1357
15,0	64003 1150	39,0	64006 1390	18,2	64204 1182	36,2	64204 1362
15,5	64003 1155	39,5	64006 1395	18,7	64204 1187	36,7	64204 1367
16,0	64003 1160			19,2	64204 1192	37,2	64204 1372
16,5	64003 1165			19,7	64204 1197	37,7	64204 1377
17,0	64003 1170			20,2	64204 1202	38,2	64204 1382
17,5	64003 1175			20,7	64204 1207	38,7	64204 1387
18,0	64003 1180			21,2	64204 1212	39,2	64204 1392
18,5	64003 1185			21,7	64204 1217	39,7	64204 1397
19,0	64003 1190			22,2	64204 1222	40,2	64204 1402
19,5	64003 1195			22,7	64204 1227	40,7	64204 1407
20,0	64003 1200						
20,5	64003 1205						
21,0	64003 1210						
21,5	64003 1215						
22,0	64003 1220						
22,5	64003 1225						
23,0	64003 1230						
23,5	64003 1235						
24,0	64003 1240						
24,5	64003 1245						
25,0	64003 1250						
25,5	64003 1255						
26,0	64003 1260						
26,5	64003 1265						

Zu **Stempel Nr. 3** kann ebenfalls eingesetzt werden:
 Also suitable for use with **punch no. 3**:
 Peuvent être utilisées également avec le **poinçon no. 3**:

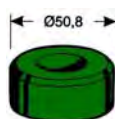

Rundmatrize Nr. 3 – Grüne Serie (Seite 4)
 round die no. 3 – green series (page 4)
 matrice ronde no. 3 – série verte (page 4)



Rundmatrize Nr. 2 – Rote Serie (Seite 11)
 round die no. 2 – red series (page 11)
 matrice ronde no. 2 – série rouge (page 11)

Blau Serie • Blue Series • Série bleue

Rundstempel
 round punch
 poinçon rond

Stempelschneide
 round punch
 poinçon rond

Rundmatrize
 round die
 matrice ronde

Rundmatrize
 round die
 matrice ronde

Nr. 7

Nr. 7.1

Nr. 6

Nr. 6

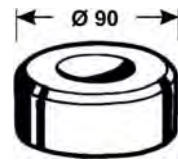
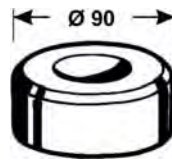
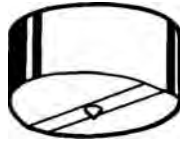
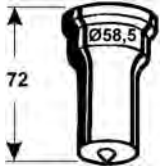

Artikel-Nr.		Artikel-Nr.		Artikel-Nr.		Artikel-Nr.	
40,0	64007 1400	60,0	65007 805 0600	40,2	64206 1402	53,2	64206 1532
41,0	64007 1410	61,0	65007 805 0610	40,7	64206 1407	53,7	64206 1537
42,0	64007 1420	62,0	65007 805 0620	41,2	64206 1412	54,2	64206 1542
43,0	64007 1430	63,0	65007 805 0630	41,7	64206 1417	54,7	64206 1547
44,0	64007 1440	64,0	65007 805 0640	42,2	64206 1422	55,2	64206 1552
45,0	64007 1450	65,0	65007 805 0650	42,7	64206 1427	55,7	64206 1557
46,0	64007 1460			43,2	64206 1432	56,2	64206 1562
47,0	64007 1470			43,7	64206 1437	56,7	64206 1567
48,0	64007 1480			44,2	64206 1442	57,2	64206 1572
49,0	64007 1490			44,7	64206 1447	57,7	64206 1577
50,0	64007 1500			45,2	64206 1452	58,2	64206 1582
51,0	64007 1510			45,7	64206 1457	58,7	64206 1587
52,0	64007 1520			46,2	64206 1462	59,2	64206 1592
53,0	64007 1530			46,7	64206 1467	59,7	64206 1597
54,0	64007 1540			47,2	64206 1472	60,2	64206 1602
55,0	64007 1550			47,7	64206 1477	60,7	64206 1607
56,0	64007 1560			48,2	64206 1482	61,2	64206 1612
57,0	64007 1570			48,7	64206 1487	61,7	64206 1617
58,0	64007 1580			49,2	64206 1492	62,2	64206 1622
				49,7	64206 1497	62,7	64206 1627
				50,2	64206 1502	63,2	64206 1632
				50,7	64206 1507	63,7	64206 1637
				51,2	64206 1512	64,2	64206 1642
				51,7	64206 1517	64,7	64206 1647
				52,2	64206 1522	65,2	64206 1652
				52,7	64206 1527	65,7	64206 1657
		Stempelschaft punch shaft tige de poinçon					
		Nr. 7					
		Artikel-Nr.					
		65007 805 0010					

Blau Serie • Blue Series • Série bleue

Vierkantstempel
square punch
poinçon carré

Vierkantstempel
square punch
poinçon carré

Vierkantstempel
square punch
poinçon carré

Vierkantmatrize
square die
matrice carrée

Vierkantmatrize
square die
matrice carrée

Nr. 3

Nr. 6

Nr. 7

Nr. 4

Nr. 6

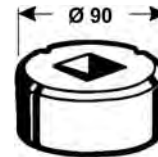
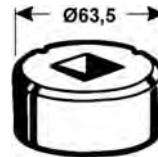
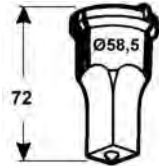
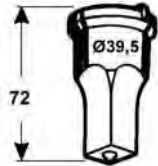
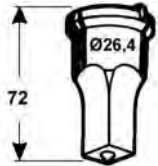

Artikel-Nr.	Artikel-Nr.	Artikel-Nr.	Artikel-Nr.	Artikel-Nr.
8,0 64003 2080	19,0 64006 2190	30,0 64007 2300	17,7 64204 2177	30,2 64206 2302
9,0 64003 2090	20,0 64006 2200	35,0 64007 2350	18,2 64204 2182	30,7 64206 2307
10,0 64003 2100	21,0 64006 2210	40,0 64007 2400	18,7 64204 2187	35,2 64206 2352
11,0 64003 2110	22,0 64006 2220		19,2 64204 2192	35,7 64206 2357
12,0 64003 2120	23,0 64006 2230		19,7 64204 2197	40,2 64206 2402
13,0 64003 2130	24,0 64006 2240		20,2 64204 2202	40,7 64206 2407
14,0 64003 2140	25,0 64006 2250		20,7 64204 2207	
15,0 64003 2150	26,0 64006 2260		21,2 64204 2212	
16,0 64003 2160	27,0 64006 2270		21,7 64204 2217	
17,0 64003 2170	28,0 64006 2280		22,2 64204 2222	
18,0 64003 2180			22,7 64204 2227	
			23,2 64204 2232	
			23,7 64204 2237	
			24,2 64204 2242	
			24,7 64204 2247	
			25,2 64204 2252	
			25,7 64204 2257	
			26,2 64204 2262	
			26,7 64204 2267	
			27,2 64204 2272	
			27,7 64204 2277	
			28,2 64204 2282	
			28,7 64204 2287	

Drehriegelstempel
hasp hole punch
poinçon trou
d'espagnolette

Nr. 3

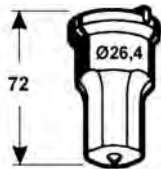

Artikel-Nr.

Ø 22,2 × 20,3

65003 38 222203

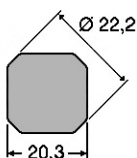

Zu **Stempel Nr. 3** kann ebenfalls eingesetzt werden:
Also suitable for use with **punch no. 3**:

Peuvent être utilisées également avec le **poinçon no. 3**:

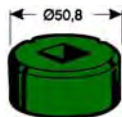

Vierkantmatrize Nr. 3

Grüne Serie (Seite 5)
square die no. 3, green series (page 5)
matrice carrée no. 3, série verte (p. 5)



Drehriegelmatrize Nr. 3

Grüne Serie (Seite 8)
hasp hole die no. 3, green series (page 8)
matrice espagn. no. 3, série verte (p. 8)

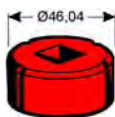

Vierkantmatrize Nr. 2

Rote Serie (Seite 12)
square die no. 2, red series (page 12)
matrice carrée no. 2, série rouge (p. 12)

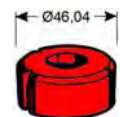

Drehriegelmatrize Nr. 2

Rote Serie (Seite 14)
hasp hole die no. 2, red series (page 14)
matrice trou d'espagn. no. 2 série rouge (p. 14)

Blau Serie • Blue Series • Série bleue

Langlochstempel
 oblong punch
 poinçon oblong

Langlochmatrize
 oblong die
 matrice oblongue

Langlochstempel
 oblong punch
 poinçon oblong

Langlochmatrize
 oblong die
 matrice oblongue

Nr. 3

Nr. 4

Nr. 6

Nr. 4

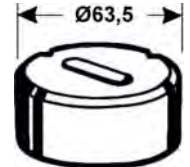
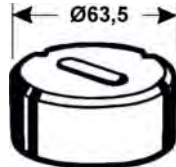

Artikel-Nr.	Artikel-Nr.	Artikel-Nr.	Artikel-Nr.
5,0 × 10 64003 3 050100	5,2 × 10,2 64204 3 052102	6,5 × 30 64006 3 065300	6,7 × 30,2 64204 3 067302
5,0 × 14 64003 3 050140	5,7 × 10,7 64204 3 057107	7,5 × 30 64006 3 075300	7,2 × 30,7 64204 3 072307
5,5 × 10 64003 3 055100	5,2 × 14,2 64204 3 052142	9,0 × 30 64006 3 090300	7,7 × 30,2 64204 3 077302
5,5 × 14 64003 3 055140	5,7 × 14,7 64204 3 057147	10,0 × 30 64006 3 100300	8,2 × 30,7 64204 3 082307
5,5 × 19 64003 3 055190	5,7 × 10,2 64204 3 057102	11,0 × 30 64006 3 110300	9,2 × 30,2 64204 3 092302
5,5 × 25 64003 3 055250	6,2 × 10,7 64204 3 062107	12,0 × 30 64006 3 120300	9,7 × 30,7 64204 3 097307
6,5 × 12 64003 3 065120	5,7 × 14,2 64204 3 057142	12,0 × 35 64006 3 120350	10,2 × 30,2 64204 3 102302
6,5 × 18 64003 3 065180	6,2 × 14,7 64204 3 062147	13,0 × 30 64006 3 130300	10,7 × 30,7 64204 3 107307
6,5 × 26 64003 3 065260	5,7 × 19,2 64204 3 057192	13,0 × 35 64006 3 130350	11,2 × 30,2 64204 3 112302
7,5 × 14 64003 3 075140	6,2 × 19,7 64204 3 062197	14,0 × 28 64006 3 140280	11,7 × 30,7 64204 3 117307
7,5 × 21 64003 3 075210	5,7 × 25,2 64204 3 057252	14,0 × 35 64006 3 140350	12,2 × 30,2 64204 3 122302
7,5 × 26 64003 3 075260	6,2 × 25,7 64204 3 062257	16,0 × 31 64006 3 160310	12,7 × 30,7 64204 3 127307
9,0 × 14 64003 3 090140	6,7 × 12,2 64204 3 067122	18,0 × 31 64006 3 180310	12,2 × 35,2 64204 3 122352
9,0 × 18 64003 3 090180	7,2 × 12,7 64204 3 072127	20,0 × 31 64006 3 200310	12,7 × 35,7 64204 3 127357
9,0 × 26 64003 3 090260	6,7 × 18,2 64204 3 067182	22,0 × 31 64006 3 220310	13,2 × 30,2 64204 3 132302
10,0 × 14 64003 3 100140	7,2 × 18,7 64204 3 072187		13,7 × 30,7 64204 3 137307
10,0 × 20 64003 3 100200	6,7 × 26,2 64204 3 067262		13,2 × 35,2 64204 3 132352
10,0 × 26 64003 3 100260	7,2 × 26,7 64204 3 072267		13,7 × 35,7 64204 3 137357
11,0 × 22 64003 3 110220	7,7 × 14,2 64204 3 077142		14,2 × 28,2 64204 3 142282
11,0 × 26 64003 3 110260	8,2 × 14,7 64204 3 082147		14,7 × 28,7 64204 3 147287
12,0 × 24 64003 3 120240	7,7 × 21,2 64204 3 077212		14,2 × 35,2 64204 3 142352
13,0 × 26 64003 3 130260	8,2 × 21,7 64204 3 082217		14,7 × 35,7 64204 3 147357
14,0 × 26 64003 3 140260	7,7 × 26,2 64204 3 077262		16,2 × 31,2 64204 3 162312
16,0 × 26 64003 3 160260	8,2 × 26,7 64204 3 082267		16,7 × 31,7 64204 3 167317
18,0 × 26 64003 3 180260	9,2 × 14,2 64204 3 092142		18,2 × 31,2 64204 3 182312
	9,7 × 14,7 64204 3 097147		18,7 × 31,7 64204 3 187317
	9,2 × 18,2 64204 3 092182		18,2 × 36,2 64204 3 182362
	9,7 × 18,7 64204 3 097187		18,7 × 36,7 64204 3 187367
	9,2 × 26,2 64204 3 092262		20,2 × 31,2 64204 3 202312
	9,7 × 26,7 64204 3 097267		20,7 × 31,7 64204 3 207317
	10,2 × 14,2 64204 3 102142		22,2 × 31,2 64204 3 222312
	10,7 × 14,7 64204 3 107147		22,7 × 31,7 64204 3 227317
	10,2 × 20,2 64204 3 102202		
	10,7 × 20,7 64204 3 107207		
	10,2 × 26,2 64204 3 102262		
	10,7 × 26,7 64204 3 107267		
	11,2 × 22,2 64204 3 112222		
	11,7 × 22,7 64204 3 117227		
	11,2 × 26,2 64204 3 112262		
	11,7 × 26,7 64204 3 117267		
	12,2 × 24,2 64204 3 122242		
	12,7 × 24,7 64204 3 127247		
	13,2 × 26,2 64204 3 132262		
	13,7 × 26,7 64204 3 137267		
	14,2 × 26,2 64204 3 142262		
	14,7 × 26,7 64204 3 147267		
	16,2 × 26,2 64204 3 162262		
	16,7 × 26,7 64204 3 167267		
	18,2 × 26,2 64204 3 182262		
	18,7 × 26,7 64204 3 187267		

Zu **Stempel Nr. 3** kann ebenfalls eingesetzt werden:
 Also suitable for use with **punch no. 3**:
 Peuvent être utilisées également avec le **poinçon no. 3**:

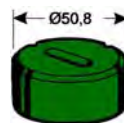

Langlochmatrize Nr. 3,
 Grüne Serie (Seite 5+6)
 oblong die no. 3,
 green series (page 5+6)
 matrice oblongue no. 3,
 série verte (page 5+6)

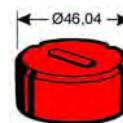

Langlochmatrize Nr. 2,
 Rote Serie (Seite 12+13)
 oblong die no. 2,
 red series (page 12+13)
 matrice oblongue no. 2,
 série rouge (page 12+13)

Blaue Serie • Blue Series • Série bleue

Langlochstempel
 oblong punch
 poinçon oblong

Langlochmatrize
 oblong die
 matrice oblongue

Rechteckstempel
 rectangular punch
 poinçon rectangulaire

Rechteckmatrize
 rectangular die
 matrice rectangulaire

Nr. 7

Nr. 6

Nr. 6

Nr. 4

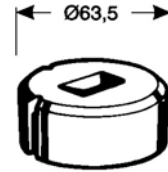
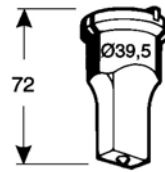
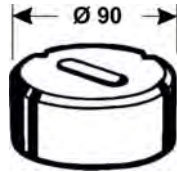

	Artikel-Nr.		Artikel-Nr.		Artikel-Nr.		Artikel-Nr.
9,0 × 40	64007 3 090400	9,2 × 40,2	64206 3 092402	6,0 × 30	64006 5 060300	6,7 × 30,7	64204 5 067307
		9,7 × 40,7	64206 3 097407	8,0 × 32	64006 5 080320	8,7 × 32,7	64204 5 087327
10,0 × 40	64007 3 100400	10,2 × 40,2	64206 3 102402	10,0 × 30	64006 5 100300	10,7 × 30,7	64204 5 107307
		10,7 × 40,7	64206 3 107407	12,0 × 36	64006 5 120360	12,7 × 36,7	64204 5 127367
11,0 × 40	64007 3 110400	11,2 × 40,2	64206 3 112402	14,0 × 36	64006 5 140360	14,7 × 36,7	64204 5 147367
		11,7 × 40,7	64206 3 117407	15,0 × 25	64006 5 150250	15,7 × 25,7	64204 5 157257
12,0 × 40	64007 3 120400	12,2 × 40,2	64206 3 122402	20,0 × 30	64006 5 200300	20,7 × 30,7	64204 5 207307
		12,7 × 40,7	64206 3 127407	22,0 × 32	64006 5 220320	22,7 × 32,7	64204 5 227327
13,0 × 40	64007 3 130400	13,2 × 40,2	64206 3 132402				
		13,7 × 40,7	64206 3 137407				
14,0 × 40	64007 3 140400	14,2 × 40,2	64206 3 142402				
		14,7 × 40,7	64206 3 147407				
16,0 × 40	64007 3 160400	16,2 × 40,2	64206 3 162402				
		16,7 × 40,7	64206 3 167407				
16,0 × 55	64007 3 160550	16,2 × 55,2	64206 3 162552				
		16,7 × 55,7	64206 3 167557				
18,0 × 40	64007 3 180400	18,2 × 40,2	64206 3 182402				
		18,7 × 40,7	64206 3 187407				
18,0 × 55	64007 3 180550	18,2 × 55,2	64206 3 182552				
		18,7 × 55,7	64206 3 187557				
20,0 × 40	64007 3 200400	20,2 × 40,2	64206 3 202402				
		20,7 × 40,7	64206 3 207407				
20,0 × 55	64007 3 200550	20,2 × 55,2	64206 3 202552				
		20,7 × 55,7	64206 3 207557				
22,0 × 44	64007 3 220440	22,2 × 44,2	64206 3 222442				
		22,7 × 44,7	64206 3 227447				
22,0 × 55	64007 3 220550	22,2 × 55,2	64206 3 222552				
		22,7 × 55,7	64206 3 227557				

Schlüssellochstempel

keyhole punch
 poinçon pour canon européen

Schlüssellochmatrize

keyhole die
 matrice pour canon européen

Nr. 6

Nr. 4

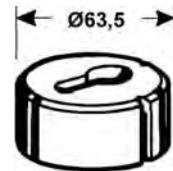
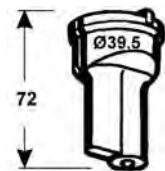

	Artikel-Nr.		Artikel-Nr.
34,0 × Ø17,5 × 10,5	65006 17 002	34,2 × Ø17,7 × 10,7	65204 17 002

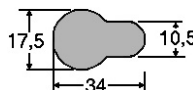

Zu Schlüssellochstempel Nr. 6 kann auch eingesetzt werden:
 Also suitable for use with keyhole punch no. 6:
 Peuvent être utilisées également avec le poinçon pour canon no. 6:

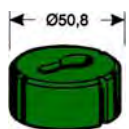

Schlüssellochmatrize Nr. 3,
 Grüne Serie (Seite 8)
 keyhole die no. 3,
 green series (page 8)
 matrice pour canon europ. no. 3,
 série verte (page 8)

Blau Serie • Blue Series • Série bleue

Eckenabrundstempel
 corner radiusing punch
 poinçon pour arrondir
 les angles

Eckenabrundstempel
 corner radiusing punch
 poinçon pour arrondir
 les angles

Eckenabrundstempel
 corner radiusing punch
 poinçon pour arrondir
 les angles

Eckenabrundmatrize
 corner radiusing die
 matrice pour arrondir
 les angles

Eckenabrundmatrize
 corner radiusing die
 matrice pour arrondir
 les angles

Nr. 3

Nr. 6

Nr. 7

Nr. 4

Nr. 6

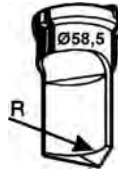
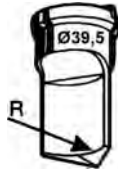
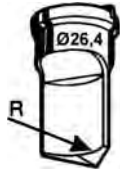

Artikel-Nr.

Radius

5 65003 37 00050
10 65003 37 00100
14 65003 37 00140

Zu **Stempel Nr. 3** kann ebenfalls eingesetzt werden:
 Also suitable for use with **punch no. 3**:
 Peuvent être utilisées également avec le **poinçon no. 3**:



Eckenabrundmatrize Nr 3
 Grüne Serie (Seite 8)
 corner radiusing die no. 3
 green series (page 8)
 matrice no. 3 pour arrondir les angles
 série verte (page 8)



Eckenabrundmatrize Nr 2
 Rote Serie (Seite 14)
 corner radiusing die no.2
 red series (page 14)
 matrice no. 2 pour arrondir les angles
 série rouge (page 14)



Artikel-Nr.

Radius

15 65006 3700150
20 65006 3700200

Trenn-Abundstempel
 shearing and one-sided
 radiusing punch
 poinçon de sectionnement et d'arrondissement simple



Artikel-Nr.

Radius

25 65007 3700250
30 65007 3700300
35 65007 3700350

Trenn-Abundmatrize
 shearing and one-sided
 radiusing die
 matrice de sectionnement et d'arrondissement simple



Artikel-Nr.

Radius

15 65204 3700150
20 65204 3700200

Trenn-Doppelabundstempel
 shearing and double-sided
 radiusing punch
 poinçon de sectionnement et d'arrondissement double



Artikel-Nr.

Radius

25 65206 3700250
30 65206 3700300
35 65206 3700350

Trenn-Doppelabundmatrize
 shearing and double-sided
 radiusing die
 matrice de sectionnement et d'arrondissement double

Nr. 7

Nr. 6

Nr. 7

Nr. 6

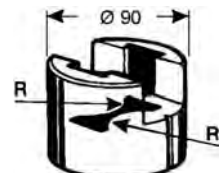
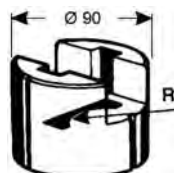

Artikel-Nr.

40 × 07 65007 35
R = 25 400725



Artikel-Nr.

40 × 07 65206 35
R = 25 400725

nur verwendbar mit
 Matrizenhalter 816
 der SV 58 Ø (Seite 59)

only for use with
 die holder no. 816 of
 the oversize punching
 attachment up to 58 Ø
 (page 59)
 uniquement pour
 utilisation avec le
 porte-matrice no. 816 du
 dispositif jusqu'à 58Ø
 (page 59)



Artikel-Nr.

40 × 07 65007 36
R = 25 400525

nur verwendbar mit
 Matrizenhalter 816
 der SV 58 Ø (Seite 59)

only for use with
 die holder no. 816 of
 the oversize punching
 attachment up to 58 Ø
 (page 59)
 uniquement pour
 utilisation avec le
 porte-matrice no. 816 du
 dispositif jusqu'à 58Ø
 (page 59)



Artikel-Nr.

40 × 07 65206 36
R = 25 400525

nur verwendbar mit
 Matrizenhalter 816
 der SV 58 Ø (Seite 59)

only for use with
 die holder no. 816 of
 the oversize punching
 attachment up to 58 Ø
 (page 59)
 uniquement pour
 utilisation avec le
 porte-matrice no. 816 du
 dispositif jusqu'à 58Ø
 (page 59)

Werkzeug-Sortimente - Stempel und Matrizen
Tooling Sets - Punches and Dies
Assortiments d'outils - poinçons et matrices

Kenn-Nr.
316

D

Werkzeugsortiment D
Tooling set D
Assortiment D

Grüne Serie
 Green Series • Série verte
 Kenn-Nr. 316.1

30 Abmessungen • dimensions

Artikel-Nr. 44081 540 85 00



Nr. 2
 Nr. 5
 Nr. 3

	Rund Ø mm	4	5	6	7	8	9	10	11	12	13
		14	15	16	17	18	20	22	26	28	30
	Vierkant mm	13									
	Langloch mm	6,5 × 26	9 × 26	11 × 26	12 × 24	13 × 26					
		14 × 26	18 × 26	20 × 31	22 × 31						

Schneidspiel • clearance • jeu : 0,7 mm

D1

Werkzeugsortiment D1
Tooling set D1
Assortiment D1

Grüne Serie
 Green Series • Série verte
 Kenn-Nr. 316.2

14 Abmessungen • dimensions

Artikel-Nr. 44081 540 86 00



Nr. 2
 Nr. 5
 Nr. 3

	Rund Ø mm	5,5	7	9	11	13	18	22	26	30
	Langloch mm	6,5 × 26	9 × 26	11 × 26	13 × 26	18 × 26				

Schneidspiel • clearance • jeu : 0,7 mm

D
blau

Werkzeugsortiment D blau
Tooling set D blue
Assortiment D bleu

Blaue Serie
 Blue Series • Série bleue
 Kenn-Nr. 316.3

30 Abmessungen • dimensions

Artikel-Nr. 44081 540 88 00



Nr. 3
 Nr. 6
 Nr. 3

	Rund Ø mm	4	5	6	7	8	9	10	11	12	13
		14	15	16	17	18	20	22	26	28	30
	Vierkant mm	13									
	Langloch mm	6,5 × 26	9 × 26	11 × 26	12 × 24	13 × 26					
		14 × 26	18 × 26	20 × 31	22 × 31						

Schneidspiel • clearance • jeu : 0,7 mm

E
blau

Werkzeugsortiment E blau
Tooling set E blue
Assortiment E bleu

Blaue Serie
 Blue Series • Série bleue
 Kenn-Nr. 316.4

30 Abmessungen • dimensions

Artikel-Nr. 42217 540 85 00



Nr. 3
 Nr. 6
 Nr. 7
 Nr. 3
 Nr. 4
 Nr. 6

	Rund Ø mm	5	6	7	8	10	11	12	13	15	16
		17	18	20	22	26	30	35	40	50	55
	Vierkant mm	13									
	Langloch mm	6,5 × 26	9 × 26	11 × 26	13 × 26	18 × 36					
		11 × 40	13 × 40	18 × 55	22 × 44						

Schneidspiel • clearance • jeu : 0,7 mm



Werkzeug-Sortimente - Stempel und Matrizen
Tooling Sets - Punches and Dies
Assortiments d'outils - poinçons et matrices

Kenn-Nr.
316

E1

Werkzeugsortiment E1
Tooling set E1
Assortiment E1

Blaue Serie
 Blue Series • Série bleue
 Kenn-Nr. 316.5

15 Abmessungen • dimensions

Artikel-Nr. 44600 540 85 00



Nr. 3
Nr. 6

Nr. 4

	10	13	17	20	22	24	30	35	38
Rund Ø mm									
	Schlüsselloch • keyhole • canon européen 34,0 × 17,5 × 10,5 mm								
	9 × 26	13 × 26	13 × 35	18 × 36	22 × 31				
Langloch mm									
Schneidspiel • clearance • jeu : 0,7 mm									

E2

Werkzeugsortiment E2
Tooling set E2
Assortiment E2

Blaue Serie
 Blue Series • Série bleue
 Kenn-Nr. 316.6

10 Abmessungen • dimensions

Artikel-Nr. 44600 540 80 00



Nr. 3
Nr. 6

Nr. 4

	11	13	16	18	22				
Rund Ø mm	24	26	28	32	39				
Schneidspiel • clearance • jeu : 0,7 mm									

B

Werkzeugsortiment B
Tooling set B
Assortiment B

Rote Serie
 Red Series • Série rouge

26 Abmessungen • dimensions

Artikel-Nr. 44001 540 85 00



Nr. 1
Nr. 4

Nr. 2

	4	5	6	7	8	9	10	11	12
Rund Ø mm	13	14	15	16	17	18	20	22	26
	Vierkant mm								
	13								
	6,5 × 26	9 × 26	11 × 26	12 × 24					
Langloch mm	13 × 26	14 × 26	18 × 26						
Schneidspiel • clearance • jeu : 0,7 mm									

Sonderstanzwerkzeuge • Special punching tools • Outils de poinçonnage spéciaux

Grüne Serie • Green Series • Série verte

Rundmatrize mit Schräge
 round die with bevel
 matrice ronde à inclinaison

Langlochmatrize mit Doppelschräge, längs und quer
 oblong die with double-bevel, longitudinal and transverse
 matrice oblongue à double inclinaison, sens long. et transversal

Nr. 3 **Nr. 3** **Nr. 3** **Nr. 3**

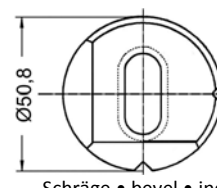
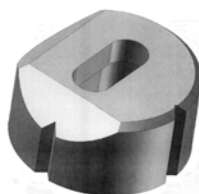
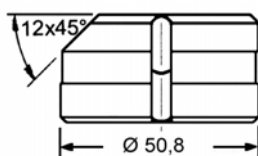
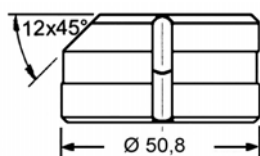

Schräge • bevel • inclinaison
 9 x 45°

	Artikel-Nr.		Artikel-Nr.		Artikel-Nr.		Artikel-Nr.	
	3,2	65203 8063 032	22,2	65203 8063 222	5,2 × 10,2	65203 8062 ..	11,2 × 26,2	65203 8062 ..
	3,7	65203 8063 037	22,7	65203 8063 227	5,7 × 10,7	65203 8062 ..	11,7 × 26,7	65203 8062 01
	4,2	65203 8063 042	23,2	65203 8063 232	5,2 × 14,2	65203 8062 ..	12,2 × 24,2	65203 8062 ..
	4,7	65203 8063 047	23,7	65203 8063 237	5,7 × 14,7	65203 8062 ..	12,2 × 24,2	65203 8062 ..
	5,2	65203 8063 052	24,2	65203 8063 242	5,7 × 10,2	65203 8062 ..	12,2 × 27,2	65203 8062 13
	5,7	65203 8063 057	24,7	65203 8063 247	6,2 × 10,7	65203 8062 ..	13,2 × 26,2	65203 8062 ..
	6,2	65203 8063 062	25,2	65203 8063 252	5,7 × 14,2	65203 8062 ..	13,7 × 26,7	65203 8062 ..
	6,7	65203 8063 067	25,7	65203 8063 257	6,2 × 14,7	65203 8062 ..	14,2 × 26,2	65203 8062 ..
	7,2	65203 8063 072	26,2	65203 8063 262	5,7 × 19,2	65203 8062 ..	14,7 × 26,7	65203 8062 02
	7,7	65203 8063 077	26,7	65203 8063 267	6,2 × 19,7	65203 8062 ..	15,2 × 27,2	65203 8062 14
	8,2	65203 8063 082	27,2	65203 8063 272	5,7 × 25,2	65203 8062 ..	16,2 × 26,2	65203 8062 ..
	8,7	65203 8063 087	27,7	65203 8063 277	6,2 × 25,7	65203 8062 ..	16,7 × 26,7	65203 8062 ..
	9,2	65203 8063 092	28,2	65203 8063 282	6,7 × 12,2	65203 8062 ..	18,2 × 26,2	65203 8062 ..
	9,7	65203 8063 097	28,7	65203 8063 287	7,2 × 12,7	65203 8062 ..	18,7 × 26,7	65203 8062 06
	10,2	65203 8063 102	29,2	65203 8063 292	6,7 × 18,2	65203 8062 ..	19,2 × 27,2	65203 8062 03
	10,7	65203 8063 107	29,7	65203 8063 297	7,2 × 18,7	65203 8062 ..		
	11,2	65203 8063 112	30,2	65203 8063 302	6,7 × 26,2	65203 8062 ..		
	11,7	65203 8063 117	30,7	65203 8063 307	7,2 × 26,7	65203 8062 ..		
	12,2	65203 8063 122	31,2	65203 8063 312	7,7 × 14,2	65203 8062 ..		
	12,7	65203 8063 127	31,7	65203 8063 317	8,2 × 14,7	65203 8062 ..		
	13,2	65203 8063 132	32,2	65203 8063 322	7,7 × 21,2	65203 8062 ..		
	13,7	65203 8063 137	32,7	65203 8063 327	8,2 × 21,7	65203 8062 ..		
	14,2	65203 8063 142	33,2	65203 8063 332	7,7 × 26,2	65203 8062 ..		
	14,7	65203 8063 147			8,2 × 26,7	65203 8062 ..		
	15,2	65203 8063 152			9,2 × 14,2	65203 8062 ..		
	15,7	65203 8063 157			9,7 × 14,7	65203 8062 ..		
	16,2	65203 8063 162			9,2 × 18,2	65203 8062 ..		
	16,7	65203 8063 167			9,7 × 18,7	65203 8062 ..		
	17,2	65203 8063 172			9,2 × 26,2	65203 8062 ..		
	17,7	65203 8063 177			9,7 × 26,7	65203 8062 ..		
	18,2	65203 8063 182			10,2 × 14,2	65203 8062 ..		
	18,7	65203 8063 187			10,7 × 14,7	65203 8062 ..		
	19,2	65203 8063 192			10,2 × 20,2	65203 8062 ..		
	19,7	65203 8063 197			10,7 × 20,7	65203 8062 ..		
	20,2	65203 8063 202			10,2 × 26,2	65203 8062 ..		
	20,7	65203 8063 207			10,7 × 26,7	65203 8062 ..		
	21,2	65203 8063 212			11,2 × 22,2	65203 8062 ..		
	21,7	65203 8063 217			11,7 × 22,7	65203 8062 ..		



Peddinghaus Anlagen & Maschinen GmbH

Peddinghaus Anlagen & Maschinen GmbH
Hasslinghauser Str. 156 • D-58285 Gevelsberg
Tel. +49 (0) 2332 / 6646-21/22/23
Fax +49 (0) 2332 / 6646-46
teile-pam@peddy.de • www.peddy.de

Sonderstanzwerkzeuge • Special punching tools • Outils de poinçonnage spéciaux

Grüne Serie • Green Series • Série verte

Flanschmatrize, rund
offset taper die, round
matrice d'aile, ronde

Flanschmatrize, Langloch quer
offset taper die, oblong hole transverse
matrice d'aile, trou oblong sens transvers.

Flanschmatrize, Langloch längs
offset taper die, oblong hole longitudinal
matrice d'aile, trou oblong sens longitud.

Nr. 8

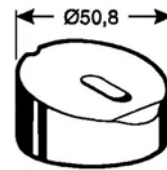
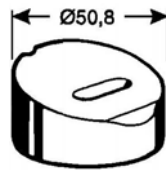
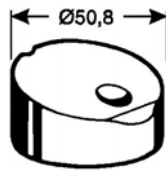

 Artikel-Nr.
64208 1...

 Artikel-Nr.
64208 4...

 Artikel-Nr.
64208 3...

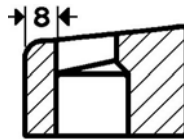

Rote Serie • Red Series • Série rouge

Flanschmatrize, rund
offset taper die, round
matrice d'aile, ronde

Flanschmatrize, Langloch quer
offset taper die, oblong hole transverse
matrice d'aile, trou oblong sens transvers.

Flanschmatrize, Langloch längs
offset taper die, oblong hole longitudinal
matrice d'aile, trou oblong sens longitud.

Nr. 7

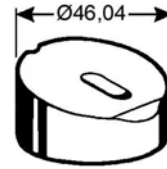
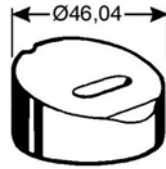
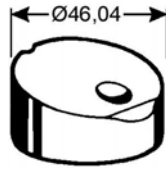

 Artikel-Nr.
64207 1...

 Artikel-Nr.
64207 4...

 Artikel-Nr.
64207 3...

Sonderstanzwerkzeuge • Special punching tools • Outils de poinçonnage spéciaux

Kenn-Nr. 317

Für Langlochstanzen bis 55 mm Länge in Winkelstahl

For punching oblong holes up to 55 mm long in angle iron

Pour poinçonner des trous oblongs jusqu'à 55 mm de longueur dans des cornières

Stempelhalterung: Sonder-Stanzvorrichtung bis 58 mm
 punch holder: oversize punching attachment up to 58 mm
 porte-poinçon: dispositif de poinçonnage jusqu'à 58 mm

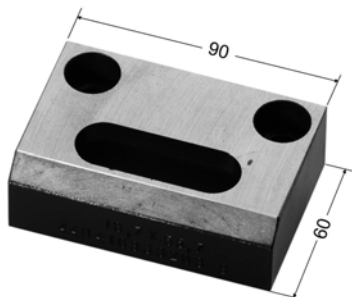
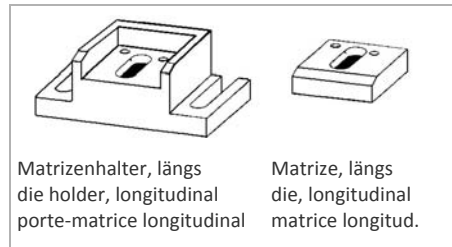
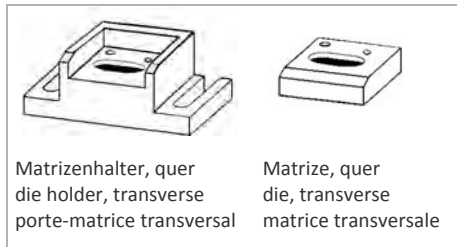

44041 6 3332 03 B
Winkelstahlmatrize 317 Langloch quer
 offset oblong die no. 317 transverse
 matrice décentrée no. 317,
 trou oblong sens transversal



44001 6 3695 22
Winkelstahlmatrize 317, Langloch längs
 offset oblong die no. 317, longitudinal
 matrice décentrée 317,
 trou oblong sens longitudinal

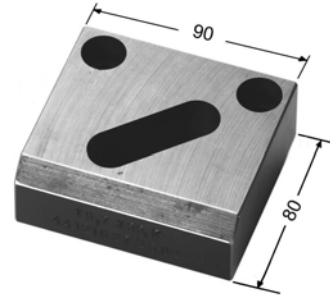

44121 6 2725 02
Winkelstahlmatrize 317, Langloch 45° rechts
 offset oblong die no. 317, 45° right
 matrice décentrée 317, trou oblong 45° à droite

44121 6 2725 03
Winkelstahlmatrize 317, Langloch 45° links
 offset oblong die no. 317, 45° left
 matrice décentrée 317, trou oblong 45° à g:

Außenmaße:
 physical dimensions:
 dimensions hors tout:

Breite • length • longueur	90 mm
Tiefe • width • largeur	60 mm
Stärke • height • hauteur	30 mm

Außenmaße:
 physical dimensions:
 dimensions hors tout:

Breite • length • longueur	90 mm
Tiefe • width • largeur	80 mm
Stärke • height • hauteur	30 mm

Außenmaße:
 physical dimensions:
 dimensions hors tout:

Breite • length • longueur	90 mm
Tiefe • width • largeur	80 mm
Stärke • height • hauteur	30 mm

Sonderstanzwerkzeuge • Special punching tools • Outils de poinçonnage spéciaux

Kenn-Nr. 318

Für Stanzungen bis Ø 22 mm • Langloch bis 26 mm Länge in U- und I-Profile

For punching round holes up to Ø 22 mm • oblong holes up to 26 mm length in channels and I-beams

Pour poinçonner des trous jusqu'à Ø 22 mm • trous oblongs jusqu'à 26 mm de longueur dans des profilés en U et en double T

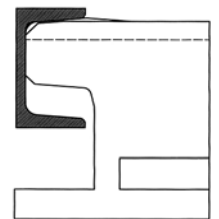
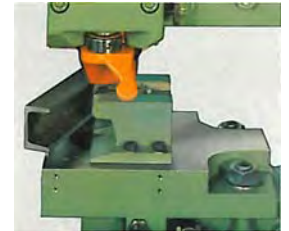

Peddimax No. 1 Hydraulic 502 Hydraulic 1250	UNP 40 • 50 • 65	UNP 80 + 100
	Flanschmatrizenhalter flange-type die holder porte-matrice d'aile	Flanschmatrizenhalter flange-type die holder porte-matrice d'aile
	44081 6 2735 15	44081 6 2735 11

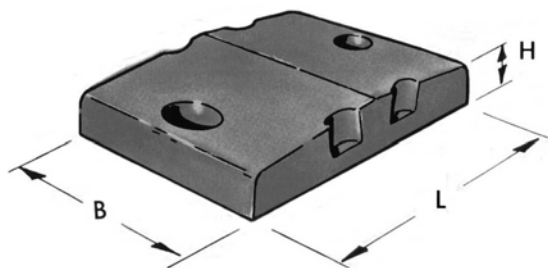

INP 40, 50 + 65

Flanschmatrize Nr. 77
offset taper die no. 77
matrice d'aile no. 77

L = 90 mm
B = 60 mm
H = 11,3 mm

INP 80 + 100

Flanschmatrize Nr. 79
offset taper die no. 79
matrice d'aile no. 79

L = 90 mm
B = 60 mm
H = 21,3 mm

Artikel-Nr. • Part no. • no. de réf.

Artikel-Nr. • Part no. • no. de réf.

	Rund	round	rond	64277 1	64279 1
	Langloch längs	oblong longitudinal	oblong longitudinal	64277 3	64279 3
	Langloch quer	oblong transverse	oblong transversal	64277 4	64279 4

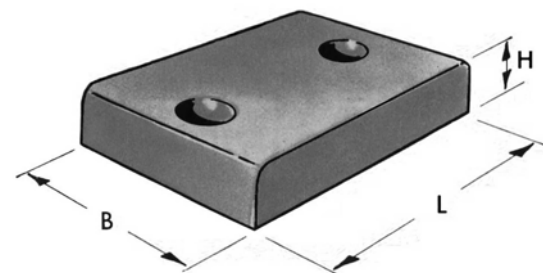

UKP

Winkelstahlmatrize Nr. 78
offset flat die no. 78
matrice no. 78 pour cornières

L = 80 mm
B = 60 mm
H = 15 mm

Artikel-Nr. • Part no. • no. de réf.

	Rund	round	rond	64278 1
	Langloch längs	oblong longitudinal	oblong longitudinal	64278 3
	Langloch quer	oblong transverse	oblong transversal	64278 4

Sonderstanzwerkzeuge • Special punching tools • Outils de poinçonnage spéciaux

Stempel und Matrizen für Sonderstanzformen

Special shape punches and dies

Poinçons et matrices de forme spéciale

Form Shape Forme					
Nr.	1	5	9	11	13
	Flachrund flat round demi-lune	Dreikant triangular triangulaire	Sechskant hexagon hexagonal	Zweikant with two flat sides à deux arrondis	Halbrund half round à un arrondi
Form Shape Forme					
Nr.	17	21	25	27	29
	Schlüsselloch rund key hole, round slot canon rond	Schlüsselloch eckig key hole, square slot canon angulaire	Bajonett rund bayonet round baionnette ronde	Bajonett eckig bayonet square baionnette angulaire	Rechteck mit Radien rectangular wit radiused corners rectangulaire aux angles arrondis
Form Shape Forme					
Nr.	34	35	36	37	
	Abrunden radiusing arrondir	Trennen und Abrunden shearing and radiusing sectionnement et arrondissement	Trennen und Doppelabrunden shearing and double-sided radiusing sectionnement et double arrondissement	Eckenabrunden corner radiusing arrondissement des angles	
Form Shape Forme					
Nr.	31	33	32	51	53
	Schlitz rechteckig rectangular slot fente rectangulaire	Schlitz halbrund half round slot fente demi-ronde	Dreikant 30° 45° 60° 90° triangular triangulaire	Schlitz rechteckig, zum Nachsetzen rectangular slot, for progressive notching fente rectangulaire, grugeage consécutif	Schlitz halbrund, zum Nachsetzen half round slot, for progressive notching fente demi-ronde, grugeage consécutif

Sonderstanzwerkzeuge • Special punching tools • Outils de poinçonnage spéciaux

Werkzeugaufnahme für Stempel Nr. 50 und Matrize Nr. 58

punching attachment for punch no. 50 and die no. 58
 dispositif pour poinçon no. 50 et matrice no. 58

- Stempelhalter • punch holder • porte-matrice 44001 198 821 A
- Stempelkeil • taper pin • clavette 44001 198 820 A
- Matrizenhalter • die holder • porte-matrice 44041 621 70 00 / 42225 620 04 00

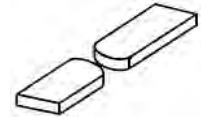

bis 60x10, R= 40

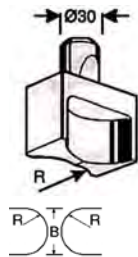

Trenn-Doppelabrund-Stempel Nr. 50

shearing and double-sided radiusing punch
 poinçon de sectionnement et d'arrondissement double

Artikel-Nr.

25 × 10 R = 15	65050 36 251015
30 × 10 R = 20	65050 36 301020
35 × 10 R = 20	65050 36 351020
40 × 10 R = 25	65050 36 401025
50 × 10 R = 30	65050 36 501030
60 × 10 R = 40	65050 36 601040

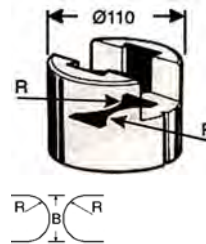

Trenn-Doppelabrund-Matrize Nr. 58

shearing and double-sided radiusing die
 matrice de sectionnement et d'arrondissement double

Artikel-Nr.

25 × 10 R = 15	65258 36 251015
30 × 10 R = 20	65258 36 301020
35 × 10 R = 20	65258 36 351020
40 × 10 R = 25	65258 36 401025
50 × 10 R = 30	65258 36 501030
60 × 10 R = 40	65258 36 601040

Kenn-Nr. 552

Rohrausklinkwerkzeuge zum Einsatz in Sonder-Stanzvorrichtung bis 58 mm Ø

Pipe notching tools for use in oversize punching attachment up to 58 mm Ø

Outils de grugeage pour tubes, pour utilisation dans le dispositif de poinçonnage jusqu'à 58 mm Ø

Rohrausklinkstempel Gr. 7

pipe notching punch size 7
 poinçon no. 7 à gruger les tubes
 Artikel-Nr. 65007 8012 ..

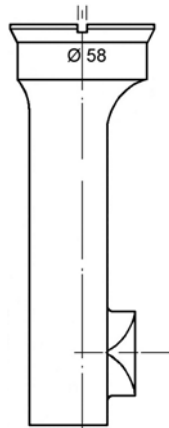
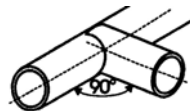

1" an 1"	= 34 mm an 34 mm
1 ¼" an 1 ¼"	= 42 mm an 42 mm
1 ½" an 1 ½"	= 48 mm an 48 mm
2" an 2"	= 60 mm an 60 mm*

*Spezial-Stempelmutter erforderlich
 *special locking nut required
 *écrou de fixation spécial nécessaire

andere Rohrabmessungen
 auf Anfrage
 other pipe sizes upon request
 d'autres dimensions de tubes sur
 demande

Rohrausklinkmatrize Gr. 6

pipe notching die size 6
 matrice no. 6 à gruger les tubes
 Artikel-Nr. 65206 8007 ..

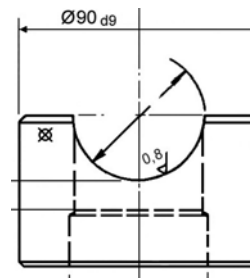

Bei Bestellung bitte Maschinentype angeben. • Please quote the machine model when ordering. • Merci de nous faire connaître le type de machine.

US Norm • U.S. Style • Type américain

zum Einsatz auf Peddinghaus CNC-Stanzanlagen
 for use on Peddinghaus CNC punching lines
 pour utilisation sur lignes de poinçonnage à commande numérique

**AFPS • AFCPS • APS
 FPDB • FPB • FPD 1120 • F-1170**

Nr. 272 Stempel
 punch
 poinçon

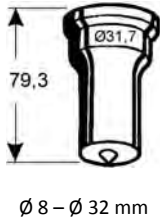

Ø 8 – Ø 32 mm

Nr. 271 Matrize
 die
 matrice

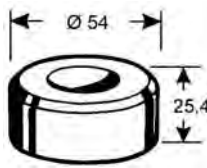

Ø 8,2 – Ø 35,2 mm

Nr. 271 Matrize mit Schräge
 die with chamfer
 matrice à inclinaison

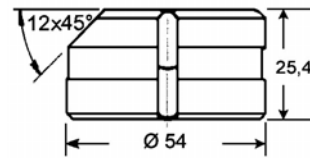

Ø 8,2 – Ø 33,7 mm

Nr. 292 Stempel
 punch
 poinçon

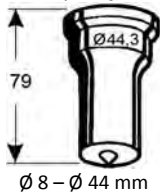

Ø 8 – Ø 44 mm

Nr. 291 Matrize
 die
 matrice

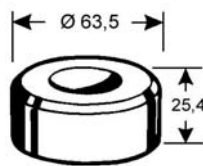

Ø 8,2 – Ø 44,7 mm

Nr. 291 Matrize mit Schräge
 die with chamfer
 matrice à inclinaison

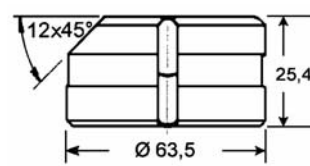

Ø 8,2 – Ø 44,7 mm

Reduzierhülse USA
 reducing sleeve
 réducteur

Nr. 272/292



Artikel-Nr. P-03020 6 2057 01

Verdrehungsschutz für Stempel Nr. 272 + Nr. 292
 parallel key for punches no. 272 + no. 292
 clavette pour poinçons no. 272 + no. 292

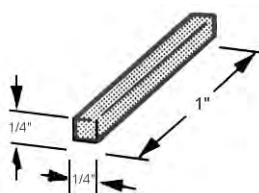

Artikel-Nr. YD3460801

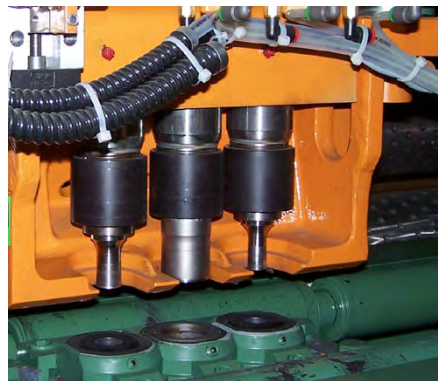







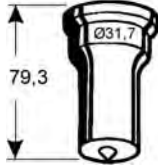
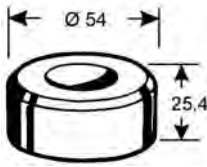
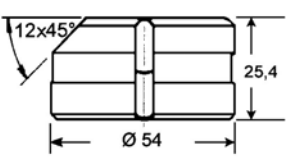

Dreistempel-Werkzeug, schaltbar, für FPDB
 Triple tool assembly to suit FPDB lines
 Dispositif de trois poinçons à sélection, pour la ligne FPDB

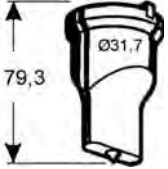
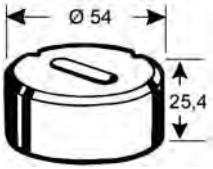
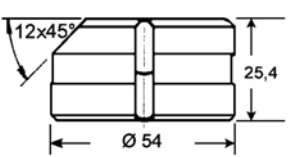
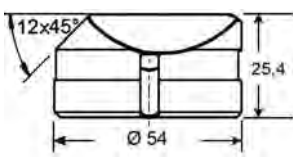
Werkzeuge tools outils	links left hand à gauche	Mitte center centre	rechts right hand à droite
Stempel Nr. punch no. poinçon no.	272	292	272
Matrize Nr. die no. matrice no.	271	291	271
Ø max. mm	32,0	44,0	32,0

US Norm • U.S. Style • Type américain

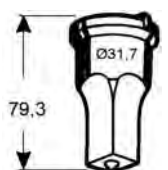
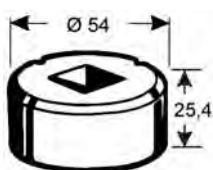
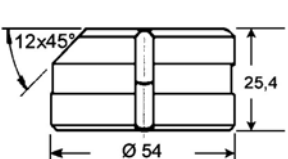
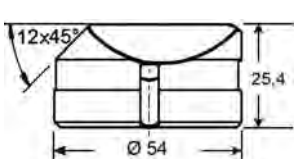
Rundstempel round punch poignon rond		Rundmatrize round die matrice ronde		Rundmatrize mit Schräge round die with chamfer matrice ronde à inclinaison	
Nr. 272		Nr. 271		Nr. 271	
					
Artikel-Nr.	Artikel-Nr.	Artikel-Nr.	Artikel-Nr.	Artikel-Nr.	Artikel-Nr.
8,0 68272 1080	26,0 68272 1260	8,2 68271 1082	26,2 68271 1262	8,2 68271 9082	26,2 68271 9262
8,5 68272 1085	26,5 68272 1265	8,7 68271 1087	26,7 68271 1267	8,7 68271 9087	26,7 68271 9267
9,0 68272 1090	27,0 68272 1270	9,2 68271 1092	27,2 68271 1272	9,2 68271 9092	27,2 68271 9272
9,5 68272 1095	27,5 68272 1275	9,7 68271 1097	27,7 68271 1277	9,7 68271 9097	27,7 68271 9277
10,0 68272 1100	28,0 68272 1280	10,2 68271 1102	28,2 68271 1282	10,2 68271 9102	28,2 68271 9282
10,5 68272 1105	28,5 68272 1285	10,7 68271 1107	28,7 68271 1287	10,7 68271 9107	28,7 68271 9287
11,0 68272 1110	29,0 68272 1290	11,2 68271 1112	29,2 68271 1292	11,2 68271 9112	29,2 68271 9292
11,5 68272 1115	29,5 68272 1295	11,7 68271 1117	29,7 68271 1297	11,7 68271 9117	29,7 68271 9297
12,0 68272 1120	30,0 68272 1300	12,2 68271 1122	30,2 68271 1302	12,2 68271 9122	30,2 68271 9302
12,5 68272 1125	30,5 68272 1305	12,7 68271 1127	30,7 68271 1307	12,7 68271 9127	30,7 68271 9307
13,0 68272 1130	31,0 68272 1310	13,2 68271 1132	31,2 68271 1312	13,2 68271 9132	31,2 68271 9312
13,5 68272 1135	31,5 68272 1315	13,7 68271 1137	31,7 68271 1317	13,7 68271 9137	31,7 68271 9317
14,0 68272 1140	32,0 68272 1320	14,2 68271 1142	32,2 68271 1322	14,2 68271 9142	32,2 68271 9322
14,5 68272 1145	33,0 68272 1330	14,7 68271 1147	32,7 68271 1327	14,7 68271 9147	32,7 68271 9327
15,0 68272 1150		15,2 68271 1152	33,2 68271 1332	15,2 68271 9152	33,2 68271 9332
15,5 68272 1155		15,7 68271 1157	33,7 68271 1337	15,7 68271 9157	33,7 68271 9337
16,0 68272 1160		16,2 68271 1162	34,2 68271 1342	16,2 68271 9162	
16,5 68272 1165		16,7 68271 1167	34,7 68271 1347	16,7 68271 9167	
17,0 68272 1170		17,2 68271 1172	35,2 68271 1352	17,2 68271 9172	
17,5 68272 1175		17,7 68271 1177		17,7 68271 9177	
18,0 68272 1180		18,2 68271 1182		18,2 68271 9182	
18,5 68272 1185		18,7 68271 1187		18,7 68271 9187	
19,0 68272 1190		19,2 68271 1192		19,2 68271 9192	
19,5 68272 1195		19,7 68271 1197		19,7 68271 9197	
20,0 68272 1200		20,2 68271 1202		20,2 68271 9202	
20,5 68272 1205		20,7 68271 1207		20,7 68271 9207	
21,0 68272 1210		21,2 68271 1212		21,2 68271 9212	
21,5 68272 1215		21,7 68271 1217		21,7 68271 9217	
22,0 68272 1220		22,2 68271 1222		22,2 68271 9222	
22,5 68272 1225		22,7 68271 1227		22,7 68271 9227	
23,0 68272 1230		23,2 68271 1232		23,2 68271 9232	
23,5 68272 1235		23,7 68271 1237		23,7 68271 9237	
24,0 68272 1240		24,2 68271 1242		24,2 68271 9242	
24,5 68272 1245		24,7 68271 1247		24,7 68271 9247	
25,0 68272 1250		25,2 68271 1252		25,2 68271 9252	
25,5 68272 1255		25,7 68271 1257		25,7 68271 9257	







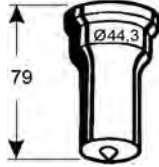
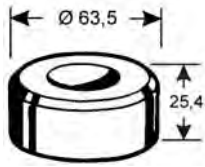
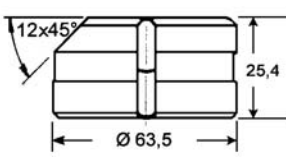

US Version • U.S. Style • Type américain

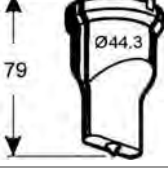
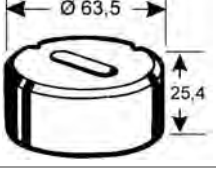
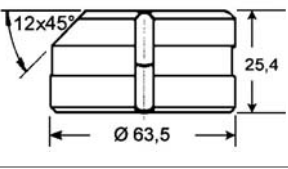
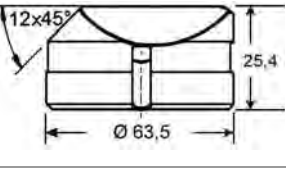
Langlochstempel oblong punch poinçon oblong	Langlochmatrize oblong die matrice oblongue	Langlochmatrize mit Schräge oblong die with chamfer matrice oblongue à inclinaison	Langlochmatrize mit Doppelschräge oblong die, double-chamfer matrice oblongue à double inclinaison																																																																												
Nr. 272	Nr. 271	Nr. 271	Nr. 271																																																																												
																																																																															
 Artikel-Nr.	 Artikel-Nr.	 Artikel-Nr.	 Artikel-Nr.																																																																												
<table border="0"> <tr><td>7,5 × 21,0</td><td>68272 3 075210</td></tr> <tr><td>10,0 × 20,0</td><td>68272 3 100200</td></tr> <tr><td>10,0 × 26,0</td><td>68272 3 100260</td></tr> <tr><td>10,0 × 31,0</td><td>68272 3 100310</td></tr> <tr><td>11,0 × 26,0</td><td>68272 3 110260</td></tr> <tr><td>12,0 × 30,0</td><td>68272 3 120300</td></tr> <tr><td>12,0 × 31,0</td><td>68272 3 120310</td></tr> <tr><td>13,0 × 30,0</td><td>68272 3 130300</td></tr> <tr><td colspan="2"> </td></tr> <tr><td>14,0 × 28,0</td><td>68272 3 140280</td></tr> <tr><td>14,0 × 31,0</td><td>68272 3 140310</td></tr> <tr><td>16,0 × 31,0</td><td>68272 3 160310</td></tr> <tr><td colspan="2"> </td></tr> <tr><td>18,0 × 31,0</td><td>68272 3 180310</td></tr> <tr><td colspan="2"> </td></tr> <tr><td>22,0 × 31,0</td><td>68272 3 220310</td></tr> </table>	7,5 × 21,0	68272 3 075210	10,0 × 20,0	68272 3 100200	10,0 × 26,0	68272 3 100260	10,0 × 31,0	68272 3 100310	11,0 × 26,0	68272 3 110260	12,0 × 30,0	68272 3 120300	12,0 × 31,0	68272 3 120310	13,0 × 30,0	68272 3 130300			14,0 × 28,0	68272 3 140280	14,0 × 31,0	68272 3 140310	16,0 × 31,0	68272 3 160310			18,0 × 31,0	68272 3 180310			22,0 × 31,0	68272 3 220310	<table border="0"> <tr><td>8,2 × 21,7</td><td>68271 3 082217</td></tr> <tr><td>10,7 × 20,7</td><td>68271 3 107207</td></tr> <tr><td>10,7 × 26,7</td><td>68271 3 107267</td></tr> <tr><td>10,7 × 31,7</td><td>68271 3 107317</td></tr> <tr><td>11,7 × 26,7</td><td>68271 3 117267</td></tr> <tr><td>12,7 × 30,7</td><td>68271 3 127307</td></tr> <tr><td>12,7 × 31,7</td><td>68271 3 127317</td></tr> <tr><td>13,7 × 30,7</td><td>68271 3 137307</td></tr> <tr><td>14,2 × 31,2</td><td>68271 3 142312</td></tr> <tr><td>14,7 × 28,7</td><td>68271 3 147287</td></tr> <tr><td>15,2 × 29,2</td><td>68271 3 152292</td></tr> <tr><td>14,7 × 31,7</td><td>68271 3 147317</td></tr> <tr><td>15,2 × 32,2</td><td>68271 3 152322</td></tr> <tr><td>16,7 × 31,7</td><td>68271 3 167317</td></tr> <tr><td>17,2 × 32,2</td><td>68271 3 172322</td></tr> <tr><td>17,7 × 32,7</td><td>68271 3 177327</td></tr> <tr><td>18,7 × 31,7</td><td>68271 3 187317</td></tr> <tr><td>19,2 × 32,2</td><td>68271 3 192322</td></tr> <tr><td>19,7 × 32,7</td><td>68271 3 197327</td></tr> <tr><td>22,7 × 31,7</td><td>68271 3 227317</td></tr> <tr><td>23,2 × 32,2</td><td>68271 3 232322</td></tr> <tr><td>23,7 × 32,7</td><td>68271 3 237327</td></tr> </table>	8,2 × 21,7	68271 3 082217	10,7 × 20,7	68271 3 107207	10,7 × 26,7	68271 3 107267	10,7 × 31,7	68271 3 107317	11,7 × 26,7	68271 3 117267	12,7 × 30,7	68271 3 127307	12,7 × 31,7	68271 3 127317	13,7 × 30,7	68271 3 137307	14,2 × 31,2	68271 3 142312	14,7 × 28,7	68271 3 147287	15,2 × 29,2	68271 3 152292	14,7 × 31,7	68271 3 147317	15,2 × 32,2	68271 3 152322	16,7 × 31,7	68271 3 167317	17,2 × 32,2	68271 3 172322	17,7 × 32,7	68271 3 177327	18,7 × 31,7	68271 3 187317	19,2 × 32,2	68271 3 192322	19,7 × 32,7	68271 3 197327	22,7 × 31,7	68271 3 227317	23,2 × 32,2	68271 3 232322	23,7 × 32,7	68271 3 237327		
7,5 × 21,0	68272 3 075210																																																																														
10,0 × 20,0	68272 3 100200																																																																														
10,0 × 26,0	68272 3 100260																																																																														
10,0 × 31,0	68272 3 100310																																																																														
11,0 × 26,0	68272 3 110260																																																																														
12,0 × 30,0	68272 3 120300																																																																														
12,0 × 31,0	68272 3 120310																																																																														
13,0 × 30,0	68272 3 130300																																																																														
14,0 × 28,0	68272 3 140280																																																																														
14,0 × 31,0	68272 3 140310																																																																														
16,0 × 31,0	68272 3 160310																																																																														
18,0 × 31,0	68272 3 180310																																																																														
22,0 × 31,0	68272 3 220310																																																																														
8,2 × 21,7	68271 3 082217																																																																														
10,7 × 20,7	68271 3 107207																																																																														
10,7 × 26,7	68271 3 107267																																																																														
10,7 × 31,7	68271 3 107317																																																																														
11,7 × 26,7	68271 3 117267																																																																														
12,7 × 30,7	68271 3 127307																																																																														
12,7 × 31,7	68271 3 127317																																																																														
13,7 × 30,7	68271 3 137307																																																																														
14,2 × 31,2	68271 3 142312																																																																														
14,7 × 28,7	68271 3 147287																																																																														
15,2 × 29,2	68271 3 152292																																																																														
14,7 × 31,7	68271 3 147317																																																																														
15,2 × 32,2	68271 3 152322																																																																														
16,7 × 31,7	68271 3 167317																																																																														
17,2 × 32,2	68271 3 172322																																																																														
17,7 × 32,7	68271 3 177327																																																																														
18,7 × 31,7	68271 3 187317																																																																														
19,2 × 32,2	68271 3 192322																																																																														
19,7 × 32,7	68271 3 197327																																																																														
22,7 × 31,7	68271 3 227317																																																																														
23,2 × 32,2	68271 3 232322																																																																														
23,7 × 32,7	68271 3 237327																																																																														
Vierkantstempel square punch poinçon carré	Vierkantmatrize square die matrice carrée	Vierkantmatrize mit Schräge square die with chamfer matrice carrée à inclinaison	Vierkantmatrize mit Doppelschräge square die, double-camfer matrice carrée à double inclinaison																																																																												
Nr. 272	Nr. 271	Nr. 271	Nr. 271																																																																												
																																																																															
 Artikel-Nr.	 Artikel-Nr.	 Artikel-Nr.	 Artikel-Nr.																																																																												
14 – 22 68272 2	14,2 – 23,2 68271 2	14,2 – 23,2																																																																													
Materialdicke • material thickness • épaisseur du matériau 4 – 9 mm 9 – 14 mm 15 – 25 mm		Schneidspiel • clearance • jeu 0,7 mm 1,2 mm 1,7 mm																																																																													

US Norm • U.S. Style • Type américain

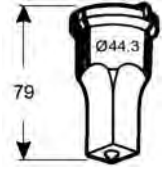
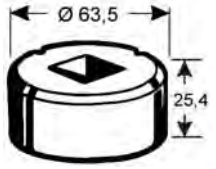
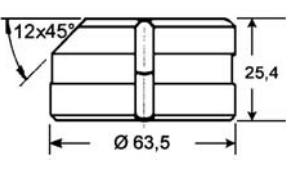
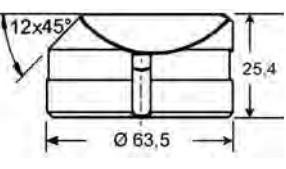
Rundstempel round punch poinçon rond		Rundmatrize round die matrice ronde		Rundmatrize mit Schräge round die with chamfer matrice ronde à inclinaison	
Nr. 292		Nr. 291		Nr. 291	
					
Artikel-Nr.	Artikel-Nr.	Artikel-Nr.	Artikel-Nr.	Artikel-Nr.	Artikel-Nr.
8,0 68292 1080	26,5 68292 1265	8,2 68291 1082	26,7 68291 1267	8,2 68291 9082	26,7 68291 9267
8,5 68292 1085	27,0 68292 1270	8,7 68291 1087	27,2 68291 1272	8,7 68291 9087	27,2 68291 9272
9,0 68292 1090	27,5 68292 1275	9,2 68291 1092	27,7 68291 1277	9,2 68291 9092	27,7 68291 9277
9,5 68292 1095	28,0 68292 1280	9,7 68291 1097	28,2 68291 1282	9,7 68291 9097	28,2 68291 9282
10,0 68292 1100	28,5 68292 1285	10,2 68291 1102	28,7 68291 1287	10,2 68291 9102	28,7 68291 9287
10,5 68292 1105	29,0 68292 1290	10,7 68291 1107	29,2 68291 1292	10,7 68291 9107	29,2 68291 9292
11,0 68292 1110	29,5 68292 1295	11,2 68291 1112	29,7 68291 1297	11,2 68291 9112	29,7 68291 9297
11,5 68292 1115	30,0 68292 1300	11,7 68291 1117	30,2 68291 1302	11,7 68291 9117	30,2 68291 9302
12,0 68292 1120	30,5 68292 1305	12,2 68291 1122	30,7 68291 1307	12,2 68291 9122	30,7 68291 9307
12,5 68292 1125	31,0 68292 1310	12,7 68291 1127	31,2 68291 1312	12,7 68291 9127	31,2 68291 9312
13,0 68292 1130	31,5 68292 1315	13,2 68291 1132	31,7 68291 1317	13,2 68291 9132	31,7 68291 9317
13,5 68292 1135	32,0 68292 1320	13,7 68291 1137	32,2 68291 1322	13,7 68291 9137	32,2 68291 9322
14,0 68292 1140	32,5 68292 1325	14,2 68291 1142	32,7 68291 1327	14,2 68291 9142	32,7 68291 9327
14,5 68292 1145	33,0 68292 1330	14,7 68291 1147	33,2 68291 1332	14,7 68291 9147	33,2 68291 9332
15,0 68292 1150	33,5 68292 1335	15,2 68291 1152	33,7 68291 1337	15,2 68291 9152	33,7 68291 9337
15,5 68292 1155	34,0 68292 1340	15,7 68291 1157	34,2 68291 1342	15,7 68291 9157	34,2 68291 9342
16,0 68292 1160	34,5 68292 1345	16,2 68291 1162	34,7 68291 1347	16,2 68291 9162	34,7 68291 9347
16,5 68292 1165	35,0 68292 1350	16,7 68291 1167	35,2 68291 1352	16,7 68291 9167	35,2 68291 9352
17,0 68292 1170	35,5 68292 1355	17,2 68291 1172	35,7 68291 1357	17,2 68291 9172	35,7 68291 9357
17,5 68292 1175	36,0 68292 1360	17,7 68291 1177	36,2 68291 1362	17,7 68291 9177	36,2 68291 9362
18,0 68292 1180	36,5 68292 1365	18,2 68291 1182	36,7 68291 1367	18,2 68291 9182	36,7 68291 9367
18,5 68292 1185	37,0 68292 1370	18,7 68291 1187	37,2 68291 1372	18,7 68291 9187	37,2 68291 9372
19,0 68292 1190	37,5 68292 1375	19,2 68291 1192	37,7 68291 1377	19,2 68291 9192	37,7 68291 9377
19,5 68292 1195	38,0 68292 1380	19,7 68291 1197	38,2 68291 1382	19,7 68291 9197	38,2 68291 9382
20,0 68292 1200	38,5 68292 1385	20,2 68291 1202	38,7 68291 1387	20,2 68291 9202	38,7 68291 9387
20,5 68292 1205	39,0 68292 1390	20,7 68291 1207	39,2 68291 1392	20,7 68291 9207	39,2 68291 9392
21,0 68292 1210	39,5 68292 1395	21,2 68291 1212	39,7 68291 1397	21,2 68291 9212	39,7 68291 9397
21,5 68292 1215	40,0 68292 1400	21,7 68291 1217	40,2 68291 1402	21,7 68291 9217	40,2 68291 9402
22,0 68292 1220	40,5 68292 1405	22,2 68291 1222	40,7 68291 1407	22,2 68291 9222	40,7 68291 9407
22,5 68292 1225	41,0 68292 1410	22,7 68291 1227	41,2 68291 1412	22,7 68291 9227	41,2 68291 9412
23,0 68292 1230	41,5 68292 1415	23,2 68291 1232	41,7 68291 1417	23,2 68291 9232	41,7 68291 9417
23,5 68292 1235	42,0 68292 1420	23,7 68291 1237	42,2 68291 1422	23,7 68291 9237	42,2 68291 9422
24,0 68292 1240	42,5 68292 1425	24,2 68291 1242	42,7 68291 1427	24,2 68291 9242	42,7 68291 9427
24,5 68292 1245	43,0 68292 1430	24,7 68291 1247	43,2 68291 1432	24,7 68291 9247	43,2 68291 9432
25,0 68292 1250	43,5 68292 1435	25,2 68291 1252	43,7 68291 1437	25,2 68291 9252	43,7 68291 9437
25,5 68292 1255	44,0 68292 1440	25,7 68291 1257	44,2 68291 1442	25,7 68291 9257	44,2 68291 9442
26,0 68292 1260		26,2 68291 1262	44,7 68291 1447	26,2 68291 9262	44,7 68291 9447

US Norm • U.S. Style • Type américain

Langlochstempel oblong punch poignon oblong	Langlochmatrize oblong die matrice oblongue	Langlochmatrize mit Schräge oblong die with chamfer matrice oblongue à inclinaison	Langlochmatrize mit Doppelschräge oblong die, double-chamfer matrice oblongue à double inclinaison
Nr. 292	Nr. 291	Nr. 291	Nr. 291
			
 Artikel-Nr.	 Artikel-Nr.	 Artikel-Nr.	 Artikel-Nr.
<p>10,0 × 30,0 68292 3 100300</p> <p>10,0 × 40,0 68292 3 100400</p> <p>12,0 × 30,0 68292 3 120300</p> <p>14,0 × 26,0 68292 3 140260</p> <p>14,0 × 40,0 68292 3 140400</p> <p>18,0 × 31,0 68292 3 180310</p> <p>18,0 × 40,0 68292 3 180400</p> <p>22,0 × 31,0 68292 3 220310</p> <p>22,0 × 40,0 68292 3 220400</p> <p>26,0 × 40,0 68292 3 260400</p>	<p>10,7 × 30,7 68291 3 107307</p> <p>10,7 × 40,7 68291 3 107407</p> <p>12,7 × 30,7 68291 3 127307</p> <p>14,7 × 26,7 68291 3 147267</p> <p>15,2 × 27,7 68291 3 152272</p> <p>14,7 × 40,7 68291 3 147407</p> <p>15,2 × 41,2 68291 3 152412</p> <p>18,7 × 31,7 68291 3 187317</p> <p>19,2 × 32,2 68291 3 192322</p> <p>19,7 × 32,7 68291 3 197327</p> <p>18,7 × 40,7 68291 3 187407</p> <p>19,2 × 41,2 68291 3 192412</p> <p>19,7 × 41,7 68291 3 197417</p> <p>22,7 × 31,7 68291 3 227317</p> <p>23,2 × 32,2 68291 3 232322</p> <p>23,7 × 32,7 68291 3 237327</p> <p>22,7 × 40,7 68291 3 227407</p> <p>23,2 × 41,2 68291 3 232412</p> <p>23,7 × 41,7 68291 3 237417</p> <p>26,7 × 40,7 68291 3 267407</p> <p>27,2 × 41,2 68291 3 272412</p> <p>27,7 × 41,7 68291 3 277417</p>		
<p>Vierkantstempel square punch poignon carré</p>	<p>Vierkantmatrize square die matrice carrée</p>	<p>Vierkantmatrize mit Schräge square die with chamfer matrice carrée à inclinaison</p>	<p>Vierkantmatrize mit Doppelschräge square die, double-chamfer matrice carrée à double inclinaison</p>
Nr. 292	Nr. 291	Nr. 291	Nr. 291
			
 Artikel-Nr.	 Artikel-Nr.	 Artikel-Nr.	 Artikel-Nr.
<p>14 – 22 68292 2</p>	<p>14,2 – 23,2 68291 2</p>	<p>14,2 – 23,2</p>	
<p>Materialdicke • material thickness • épaisseur du matériau</p> <p>4 – 9 mm</p> <p>9 – 14 mm</p> <p>15 – 25 mm</p>		<p>Schneidspiel • clearance • jeu</p> <p>0,7 mm</p> <p>1,2 mm</p> <p>1,7 mm</p>	

MUBEA-Norm • MUBEA Style • Type MUBEA

Stempel
 punch
 poinçon **Nr. 51**

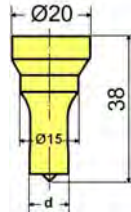

Ø 3 – Ø 15 mm
 MBN 50505-1

Stempel
 punch
 poinçon **Nr. 52**

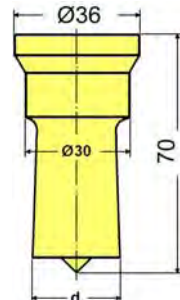

Ø 15,5 – Ø 30,0 mm
 MBN 50505-2

Stempel
 punch
 poinçon **Nr. 53**

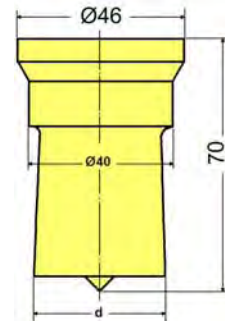

Ø 30,5 – Ø 40,0 mm
 MBN 50505-3

Matrize
 die
 matrice **Nr. 33**

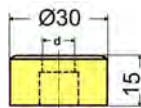

Ø 3,2 – Ø 16,2 mm
 MBN 50633

Matrize
 die
 matrice **Nr. 38**

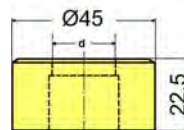

Ø 15,7 – Ø 31,7 mm
 MBN 50638

Matrize
 die
 matrice **Nr. 39**

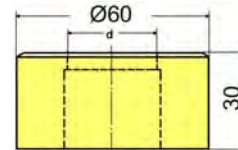

Ø 30,7 – Ø 42,2 mm
 MBN 50639

Reduzierungen • reducers • réducteurs

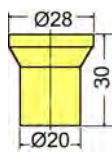

Stempelbeilage
 punch sleeve
 garniture de poinçon
 10505 290 00 00

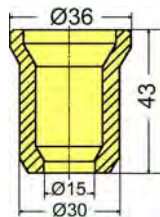

Einsatzbuchse 30/15
 punch reducing sleeve
 réducteur poinçon
 10505 313 00 00

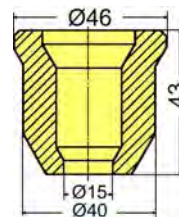

Einsatzbuchse IV/I
 punch reducing sleeve
 réducteur poinçon
 10505 314 00 00

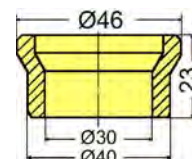

Einsatzbuchse 40/30
 punch reducing sleeve
 réducteur poinçon
 10505 315 00 00

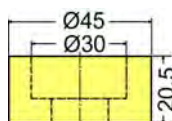

Matrizenreduzierung 45/30
 die reducing socket
 réducteur matrice
 10506 061 00 00



Matrizenreduzierung 60/30
 die reducing socket
 réducteur matrice
 10506 062 00 00

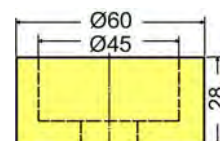

Matrizenreduzierung 60/45
 die reducing socket
 réducteur matrice
 10506 063 00 00

MUBEA-Norm • MUBEA Style • Type MUBEA

Rundstempel
 round punch
 poinçon rond

Rundmatrize
 round die
 matrice ronde

Rundstempel
 round punch
 poinçon rond

Rundmatrize
 round die
 matrice ronde

Rundstempel
 round punch
 poinçon rond

Rundmatrize
 round die
 matrice ronde

Nr. 51

Nr. 33

Nr. 52

Nr. 38

Nr. 53

Nr. 39

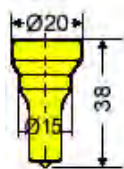

MBN 50505-1



MBN 50633

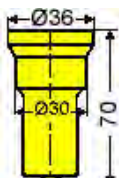

MBN 50505-2



MBN 50638

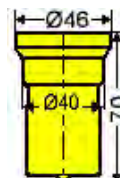

MBN 50505-3

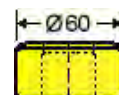

MBN 50639

Artikel-Nr.	Artikel-Nr.	Artikel-Nr.	Artikel-Nr.	Artikel-Nr.	Artikel-Nr.
3,0 15051 1030	3,2 10633 1032	15,5 15052 1155	15,7 10638 1157	30,5 15053 1305	30,7 10639 1307
3,5 15051 1035	3,7 10633 1037	16,0 15052 1160	16,2 10638 1162	31,0 15053 1310	31,2 10639 1312
4,0 15051 1040	4,2 10633 1042	16,5 15052 1165	16,7 10638 1167	31,5 15053 1315	31,7 10639 1317
4,5 15051 1045	4,7 10633 1047	17,0 15052 1170	17,2 10638 1172	32,0 15053 1320	32,2 10639 1322
5,0 15051 1050	5,2 10633 1052	17,5 15052 1175	17,7 10638 1177	32,5 15053 1325	32,7 10639 1327
5,5 15051 1055	5,7 10633 1057	18,0 15052 1180	18,2 10638 1182	33,0 15053 1330	33,2 10639 1332
6,0 15051 1060	6,2 10633 1062	18,5 15052 1185	18,7 10638 1187	33,5 15053 1335	33,7 10639 1337
6,5 15051 1065	6,7 10633 1067	19,0 15052 1190	19,2 10638 1192	34,0 15053 1340	34,2 10639 1342
7,0 15051 1070	7,2 10633 1072	19,5 15052 1195	19,7 10638 1197	34,5 15053 1345	34,7 10639 1347
7,5 15051 1075	7,7 10633 1077	20,0 15052 1200	20,2 10638 1202	35,0 15053 1350	35,2 10639 1352
8,0 15051 1080	8,2 10633 1082	20,5 15052 1205	20,7 10638 1207	35,5 15053 1355	35,7 10639 1357
8,5 15051 1085	8,7 10633 1087	21,0 15052 1210	21,2 10638 1212	36,0 15053 1360	36,2 10639 1362
9,0 15051 1090	9,2 10633 1092	21,5 15052 1215	21,7 10638 1217	36,5 15053 1365	36,7 10639 1367
9,5 15051 1095	9,7 10633 1097	22,0 15052 1220	22,2 10638 1222	37,0 15053 1370	37,2 10639 1372
10,0 15051 1100	10,2 10633 1102	22,5 15052 1225	22,7 10638 1227	37,5 15053 1375	37,7 10639 1377
10,5 15051 1105	10,7 10633 1107	23,0 15052 1230	23,2 10638 1232	38,0 15053 1380	38,2 10639 1382
11,0 15051 1110	11,2 10633 1112	23,5 15052 1235	23,7 10638 1237	38,5 15053 1385	38,7 10639 1387
11,5 15051 1115	11,7 10633 1117	24,0 15052 1240	24,2 10638 1242	39,0 15053 1390	39,2 10639 1392
12,0 15051 1120	12,2 10633 1122	24,5 15052 1245	24,7 10638 1247	39,5 15053 1395	39,7 10639 1397
12,5 15051 1125	12,7 10633 1127	25,0 15052 1250	25,2 10638 1252	40,0 15053 1400	40,2 10639 1402
13,0 15051 1130	13,2 10633 1132	25,5 15052 1255	25,7 10638 1257		40,7 10639 1407
13,5 15051 1135	13,7 10633 1137	26,0 15052 1260	26,2 10638 1262		41,2 10639 1412
14,0 15051 1140	14,2 10633 1142	26,5 15052 1265	26,7 10638 1267		41,7 10639 1417
14,5 15051 1145	14,7 10633 1147	27,0 15052 1270	27,2 10638 1272		42,2 10639 1422
15,0 15051 1150	15,2 10633 1152	27,5 15052 1275	27,7 10638 1277		
	15,7 10633 1157	28,0 15052 1280	28,2 10638 1282		
	16,2 10633 1162	28,5 15052 1285	28,7 10638 1287		
		29,0 15052 1290	29,2 10638 1292		
		29,5 15052 1295	29,7 10638 1297		
		30,0 15052 1300	30,2 10638 1302		
			30,7 10638 1307		
			31,2 10638 1312		
			31,7 10638 1317		



Peddinghaus Anlagen & Maschinen GmbH

Peddinghaus Anlagen & Maschinen GmbH
 Hasslinghauser Str. 156 • D-58285 Gevelsberg
 Tel. +49 (0) 2332 / 6646-21/22/23
 Fax +49 (0) 2332 / 6646-46
 teile-pam@peddy.de • www.peddy.de

MUBEA-Norm • MUBEA Style • Type MUBEA

Vierkantstempel
square punch
poinçon carré

Vierkantmatrize
square die
matrice carrée

Vierkantmatrize
square die
matrice carrée

Vierkantstempel
square punch
poinçon carré

Vierkantmatrize
square die
matrice carrée

Nr. 52 Nr. 33 Nr. 38 Nr. 53 Nr. 39

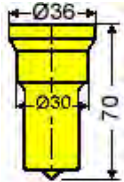

MBN 50505-2

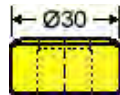

MBN 50633

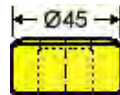



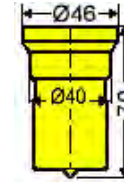

MBN 50638

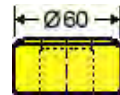

MBN 50505-3



MBN 50639

	Artikel-Nr.		Artikel-Nr.		Artikel-Nr.		Artikel-Nr.		Artikel-Nr.						
	4,0	15052	2040	4,2	10633	2042	11,7	10638	2117	21,5	15053	2215	21,7	10639	2217
	4,5	15052	2045	4,7	10633	2047	12,2	10638	2122	22,0	15053	2220	22,2	10639	2222
	5,0	15052	2050	5,2	10633	2052	12,7	10638	2127	22,5	15053	2225	22,7	10639	2227
	5,5	15052	2055	5,7	10633	2057	13,2	10638	2132	23,0	15053	2230	23,2	10639	2232
	6,0	15052	2060	6,2	10633	2062	13,7	10638	2137	23,5	15053	2235	23,7	10639	2237
	6,5	15052	2065	6,7	10633	2067	14,2	10638	2142	24,0	15053	2240	24,2	10639	2242
	7,0	15052	2070	7,2	10633	2072	14,7	10638	2147	24,5	15053	2245	24,7	10639	2247
	7,5	15052	2075	7,7	10633	2077	15,2	10638	2152	25,0	15053	2250	25,2	10639	2252
	8,0	15052	2080	8,2	10633	2082	15,7	10638	2157	25,5	15053	2255	25,7	10639	2257
	8,5	15052	2085	8,7	10633	2087	16,2	10638	2162	26,0	15053	2260	26,2	10639	2262
	9,0	15052	2090	9,2	10633	2092	16,7	10638	2167	26,5	15053	2265	26,7	10639	2267
	9,5	15052	2095	9,7	10633	2097	17,2	10638	2172	27,0	15053	2270	27,2	10639	2272
	10,0	15052	2100	10,2	10633	2102	17,7	10638	2177	27,5	15053	2275	27,7	10639	2277
	10,5	15052	2105	10,7	10633	2107	18,2	10638	2182	28,0	15053	2280	28,2	10639	2282
	11,0	15052	2110	11,2	10633	2112	18,7	10638	2187				28,7	10639	2287
	11,5	15052	2115				19,2	10638	2192				29,2	10639	2292
	12,0	15052	2120				19,7	10638	2197						
	12,5	15052	2125				20,2	10638	2202						
	13,0	15052	2130				20,7	10638	2207						
	13,5	15052	2135				21,2	10638	2212						
	14,0	15052	2140				21,7	10638	2217						
	14,5	15052	2145				22,2	10638	2222						
	15,0	15052	2150												
	15,5	15052	2155												
	16,0	15052	2160												
	16,5	15052	2165												
	17,0	15052	2170												
	17,5	15052	2175												
	18,0	15052	2180												
	18,5	15052	2185												
	19,0	15052	2190												
	19,5	15052	2195												
	20,0	15052	2200												
	20,5	15052	2205												
	21,0	15052	2210												

MUBEA-Norm • MUBEA Style • Type MUBEA

Langlochstempel
 oblong punch
 poinçon oblong

Langlochmatrize
 oblong die
 matrice oblongue

Langlochstempel
 oblong punch
 poinçon oblong

Langlochmatrize
 oblong die
 matrice oblongue

Nr. 52

Nr. 33

Nr. 52

Nr. 38

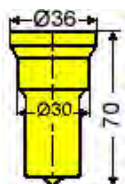

MBN 50505-2





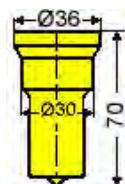

MBN 50633

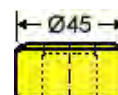

MBN 50505-2



MBN 50638

	Artikel-Nr.		Artikel-Nr.		Artikel-Nr.		Artikel-Nr.
5,0 × 10,0	15052 3050100	5,3 × 10,3	10633 3053103	5,0 × 20,0	15052 3050200	5,3 × 20,3	10638 3053203
		6,0 × 11,0	10633 3060110			6,0 × 21,0	10638 3060210
5,0 × 13,0	15052 3050130	5,3 × 13,3	10633 3053133	5,0 × 25,0	15052 3050250	5,3 × 25,3	10638 3053253
		6,0 × 14,0	10633 3060140			6,0 × 26,0	10638 3060260
5,0 × 15,0	15052 3050150	5,3 × 15,3	10633 3053153	5,5 × 20,0	15052 3055200	5,8 × 20,3	10638 3058203
		6,0 × 16,0	10633 3060160			6,5 × 21,0	10638 3065210
5,5 × 11,0	15052 3055110	5,8 × 11,3	10633 3058113	5,5 × 25,0	15052 3055250	5,8 × 25,3	10638 3058253
		6,5 × 12,0	10633 3065120			6,5 × 26,0	10638 3065260
5,5 × 13,0	15052 3055130	5,8 × 13,3	10633 3058133	6,5 × 20,0	15052 3065200	6,8 × 20,3	10638 3068203
		6,5 × 14,0	10633 3065140			7,5 × 21,0	10638 3075210
5,5 × 15,0	15052 3055150	5,8 × 15,3	10633 3058153	6,5 × 25,0	15052 3065250	6,8 × 25,3	10638 3068253
		6,5 × 16,0	10633 3065160			7,5 × 26,0	10638 3075260
6,5 × 13,0	15052 3065130	6,8 × 13,3	10633 3068133	6,5 × 30,0	15052 3065300	6,8 × 30,3	10638 3068303
		7,5 × 14,0	10633 3075140			7,5 × 31,0	10638 3075310
6,5 × 15,0	15052 3065150	6,8 × 15,3	10633 3068153	7,0 × 20,0	15052 3070200	7,3 × 20,3	10638 3073203
		7,5 × 16,0	10633 3075160			8,0 × 21,0	10638 3080210
7,0 × 15,0	15052 3070150	7,3 × 15,3	10633 3073153	7,0 × 25,0	15052 3070250	7,3 × 25,3	10638 3073253
		8,0 × 16,0	10633 3080160			8,0 × 26,0	10638 3080260
8,0 × 13,0	15052 3080130	8,3 × 13,3	10633 3083133	7,0 × 30,0	15052 3070300	7,3 × 30,3	10638 3073303
		9,0 × 14,0	10633 3090140			8,0 × 31,0	10638 3080310
9,0 × 13,0	15052 3090130	9,3 × 13,3	10633 3093133	8,0 × 16,0	15052 3080160	8,3 × 16,3	10638 3083163
		10,0 × 14,0	10633 3100140			9,0 × 17,0	10638 3090170
9,5 × 13,0	15052 3095130	9,8 × 13,3	10633 3098133	8,0 × 20,0	15052 3080200	8,3 × 20,3	10638 3083203
		10,5 × 14,0	10633 3105140			9,0 × 21,0	10638 3090210
9,5 × 15,0	15052 3095150	9,8 × 15,3	10633 3098153	8,0 × 25,0	15052 3080250	8,3 × 25,3	10638 3083253
		10,5 × 16,0	10633 3105160			9,0 × 26,0	10638 3090260
10,5 × 15,0	15052 3105150	10,8 × 15,3	10633 3108153	8,0 × 30,0	15052 3080300	8,3 × 30,3	10638 3083303
		11,5 × 16,0	10633 3115160			9,0 × 31,0	10638 3090310
11,0 × 15,0	15052 3110150	11,3 × 15,3	10633 3113153	9,0 × 18,0	15052 3090180	9,3 × 18,3	10638 3093183
		12,0 × 16,0	10633 3120160			10,0 × 19,0	10638 3100190
				9,0 × 20,0	15052 3090200	9,3 × 20,3	10638 3093203
				9,0 × 25,0	15052 3090250	10,0 × 21,0	10638 3100210
						9,3 × 25,3	10638 3093253
						10,0 × 26,0	10638 3100260



Peddinghaus Anlagen & Maschinen GmbH

Peddinghaus Anlagen & Maschinen GmbH
Hasslinghauser Str. 156 • D-58285 Gevelsberg
Tel. +49 (0) 2332 / 6646-21/22/23
Fax +49 (0) 2332 / 6646-46
teile-pam@peddy.de • www.peddy.de

MUBEA-Norm • MUBEA Style • Type MUBEA

Langlochstempel
oblong punch
poinçon oblong

Langlochmatrize
oblong die
matrice oblongue

Langlochstempel
oblong punch
poinçon oblong

Langlochmatrize
oblong die
matrice oblongue

Nr. 52

Nr. 38

Nr. 52

Nr. 38

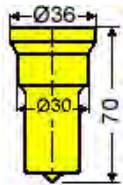

MBN 50505-2

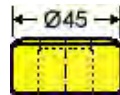



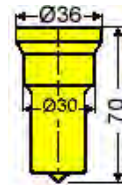

MBN 50638

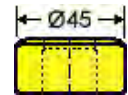

MBN 50505-2



MBN 50638

 Artikel-Nr.	 Artikel-Nr.	 Artikel-Nr.	 Artikel-Nr.
9,0 × 30,0 15052 3090300	9,3 × 30,3 10638 3093303	13,5 × 20,0 15052 3135200	13,8 × 20,3 10638 3138203
9,5 × 20,0 15052 3095200	10,0 × 31,0 10638 3100310	13,5 × 25,0 15052 3135250	14,5 × 21,0 10638 3145210
9,5 × 25,0 15052 3095250	9,8 × 20,3 10638 3098203	13,5 × 30,0 15052 3135300	13,8 × 25,3 10638 3138253
9,5 × 30,0 15052 3095300	10,5 × 21,0 10638 3105210	14,0 × 20,0 15052 3140200	14,5 × 26,0 10638 3145260
10,5 × 21,0 15052 3105210	9,8 × 25,3 10638 3098253	14,0 × 25,0 15052 3140250	13,8 × 30,3 10638 3138303
10,5 × 25,0 15052 3105250	10,5 × 26,0 10638 3105260	14,0 × 30,0 15052 3140300	14,5 × 31,0 10638 3145310
10,5 × 30,0 15052 3105300	9,8 × 30,3 10638 3098303	16,0 × 25,0 15052 3160250	14,3 × 20,3 10638 3143203
11,0 × 20,0 15052 3110200	10,5 × 31,0 10638 3105310	16,0 × 30,0 15052 3160300	15,0 × 21,0 10638 3150210
11,0 × 25,0 15052 3110250	10,8 × 21,3 10638 3108213	17,5 × 25,0 15052 3175250	14,3 × 25,3 10638 3143253
11,0 × 30,0 15052 3110300	11,5 × 22,0 10638 3115220	17,5 × 30,0 15052 3175300	15,0 × 26,0 10638 3150260
12,0 × 20,0 15052 3120200	10,8 × 25,3 10638 3108253	19,0 × 25,0 15052 3190250	14,3 × 30,3 10638 3143303
12,0 × 25,0 15052 3120250	11,5 × 26,0 10638 3115260	19,0 × 30,0 15052 3190300	15,0 × 31,0 10638 3150310
12,0 × 30,0 15052 3120300	10,8 × 30,3 10638 3108303	20,5 × 25,0 15052 3205250	16,3 × 25,3 10638 3163253
13,0 × 20,0 15052 3130200	11,5 × 31,0 10638 3115310	20,5 × 30,0 15052 3205300	17,0 × 26,0 10638 3170260
13,0 × 25,0 15052 3130250	11,3 × 20,3 10638 3113203	22,5 × 30,0 15052 3225300	16,3 × 30,3 10638 3163303
13,0 × 30,0 15052 3130300	12,0 × 21,0 10638 3120210	24,0 × 30,0 15052 3240300	17,0 × 31,0 10638 3170310
	11,3 × 25,3 10638 3113253	25,5 × 30,0 15052 3255300	17,8 × 25,3 10638 3178253
	12,0 × 26,0 10638 3120260		18,5 × 26,0 10638 3185260
	11,3 × 30,3 10638 3113303		17,8 × 30,3 10638 3178303
	12,0 × 31,0 10638 3120310		18,5 × 31,0 10638 3185310
	12,3 × 20,3 10638 3123203		19,3 × 25,3 10638 3193253
	13,0 × 21,0 10638 3130210		20,0 × 26,0 10638 3200260
	12,3 × 25,3 10638 3123253		19,3 × 30,3 10638 3193303
	13,0 × 26,0 10638 3130260		20,0 × 31,0 10638 3200310
	12,3 × 30,3 10638 3123303		20,8 × 25,3 10638 3208253
	13,0 × 31,0 10638 3130310		21,5 × 26,0 10638 3215260
	13,3 × 20,3 10638 3133203		20,8 × 30,3 10638 3208303
	14,0 × 21,0 10638 3140210		21,5 × 31,0 10638 3215310
	13,3 × 25,3 10638 3133253		22,8 × 30,3 10638 3228303
	14,0 × 26,0 10638 3140260		23,5 × 31,0 10638 3235310
	13,3 × 30,3 10638 3133303		24,3 × 30,3 10638 3243303
	14,0 × 31,0 10638 3140310		25,0 × 31,0 10638 3250310
			25,8 × 30,3 10638 3258303
			26,5 × 31,0 10638 3265310

MUBEA-Norm • MUBEA Style • Type MUBEA

Langlochstempel
 oblong punch
 poinçon oblong

Langlochmatrize
 oblong die
 matrice oblongue

Langlochstempel
 oblong punch
 poinçon oblong

Langlochmatrize
 oblong die
 matrice oblongue

Nr. 53

Nr. 39

Nr. 53

Nr. 39

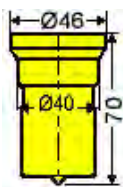

MBN 50505-3

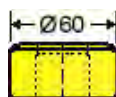



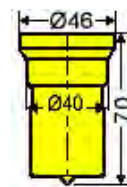

MBN 50639

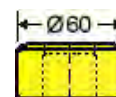

MBN 50505-3



MBN 50639

	Artikel-Nr.		Artikel-Nr.		Artikel-Nr.		Artikel-Nr.
11,0 × 35,0	15053 3110350	11,3 × 35,3	10639 3113353	19,0 × 35,0	15053 3190350	19,3 × 35,3	10639 3193353
		12,0 × 36,0	10639 3120360			20,0 × 36,0	10639 3200360
11,0 × 40,0	15053 3110400	11,3 × 40,3	10639 3113403	19,0 × 40,0	15053 3190400	19,3 × 40,3	10639 3193403
		12,0 × 41,0	10639 3120410			20,0 × 41,0	10639 3200410
13,5 × 35,0	15053 3135350	13,8 × 35,3	10639 3138353	20,5 × 35,0	15053 3205350	20,8 × 35,3	10639 3208353
		14,5 × 36,0	10639 3145360			21,5 × 36,0	10639 3215360
13,5 × 40,0	15053 3135400	13,8 × 40,3	10639 3138403	20,5 × 40,0	15053 3205400	20,8 × 40,3	10639 3208403
		14,5 × 41,0	10639 3145410			21,5 × 41,0	10639 3215410
14,0 × 35,0	15053 3140350	14,3 × 35,3	10639 3143353	22,5 × 35,0	15053 3225350	22,8 × 35,3	10639 3228353
		15,0 × 36,0	10639 3150360			23,5 × 36,0	10639 3235360
14,0 × 40,0	15053 3140400	14,3 × 40,3	10639 3143403	22,5 × 40,0	15053 3225400	22,8 × 40,3	10639 3228403
		15,0 × 41,0	10639 3150410			23,5 × 41,0	10639 3235410
16,0 × 35,0	15053 3160350	16,3 × 35,3	10639 3163353	24,0 × 40,0	15053 3240400	24,3 × 40,3	10639 3243403
		17,0 × 36,0	10639 3170360			25,0 × 41,0	10639 3250410
16,0 × 40,0	15053 3160400	16,3×40,3	10639 3163403	25,5 × 40,0	15053 3255400	25,8 × 40,3	10639 3258403
		17,0×41,0	10639 3170410			26,5 × 41,0	10639 3265410
17,5 × 35,0	15053 3175350	17,8×35,3	10639 3178353	26,0 × 40,0	15053 3260400	26,3 × 40,3	10639 3263403
		18,5×36,0	10639 3185360			27,0 × 41,0	10639 3270410
17,5 × 40,0	15053 3175400	17,8×40,3	10639 3178403	27,0 × 40,0	15053 3270400	27,3 × 40,3	10639 3273403
		18,5×41,0	10639 3185410			28,0 × 41,0	10639 3280410

Peddy • Peddicat 275H • 21/16 • 36 RP 10



Peddy

ab Maschinen-Nr. • from serial no. • à partir du no. de fabr. • PA 2000

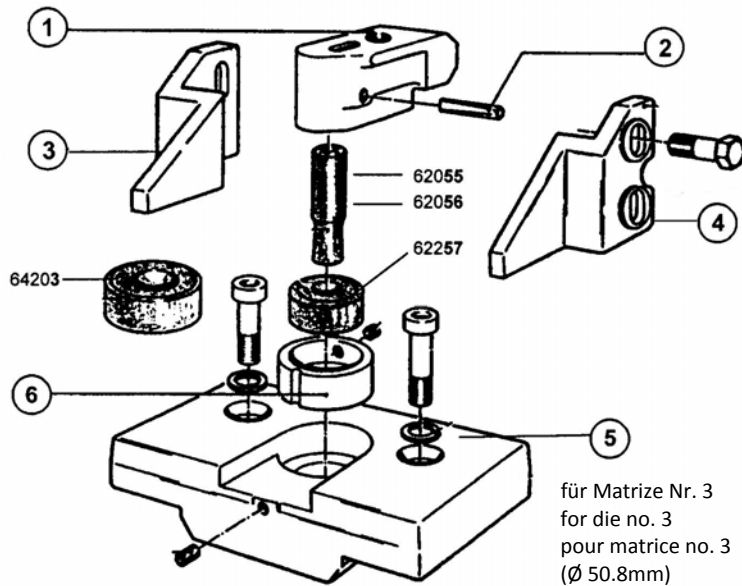

1	Stempelhalter punch holder porte-poinçon	40610 199 953 C
2	Stempelkeil taper pin clavette	40610 540 81 02 M
3	Abstreifer links stripper, l.h. dévêtisseur à g.	40610 540 81 06
4	Abstreifer rechts stripper, r.h. dévêtisseur à dr.	40610 540 81 05
5	Matrizenhalter die holder porte-matrice	40610 199 954 E

nicht im Lieferumfang enthalten:
 not included in the scope of delivery.
 non compris de la livraison:

6	Reduziereinsatz reducing socket réducteur	40610 199 957
---	---	---------------

Normal-Stanzwerkzeug, komplett
 Standard punching attachment complete
 Dispositif de poinçonnage standard complet
 Artikel-Nr. 40610 5 4081 00 A

Peddy • Peddicat 275H • 21/16 • 36 RP 10

Rundstempel round punch poinçon rond	Rundstempel round punch poinçon rond	Rundmatrize round die matrice ronde	Rundmatrize round die matrice ronde	Rundmatrize round die matrice ronde
--	--	---	---	---

Nr. 55	Nr. 56	Nr. 57	Nr. 3*	Nr. 3*
--------	--------	--------	--------	--------

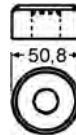
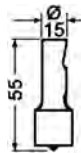
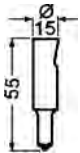

Artikel-Nr.	Artikel-Nr.	Artikel-Nr.	Artikel-Nr.	Artikel-Nr.
-------------	-------------	-------------	-------------	-------------

3,0	62055 1030
3,5	62055 1035
4,0	62055 1040
4,5	62055 1045
5,0	62055 1050
5,5	62055 1055
6,0	62055 1060
6,5	62055 1065
7,0	62055 1070
7,5	62055 1075
8,0	62055 1080
8,5	62055 1085
9,0	62055 1090
9,5	62055 1095
10,0	62055 1100
10,5	62055 1105
11,0	62055 1110
11,5	62055 1115
12,0	62055 1120
12,5	62055 1125
13,0	62055 1130
13,5	62055 1135
14,0	62055 1140
14,5	62055 1145
15,0	62055 1150

15,5	62056 1155
16,0	62056 1160
16,5	62056 1165
17,0	62056 1170
17,5	62056 1175
18,0	62056 1180
18,5	62056 1185
19,0	62056 1190
19,5	62056 1195
20,0	62056 1200
20,5	62056 1205
21,0	62056 1210
21,5	62056 1215
22,0	62056 1220

3,2	62257 1032
3,7	62257 1037
4,2	62257 1042
4,7	62257 1047
5,2	62257 1052
5,7	62257 1057
6,2	62257 1062
6,7	62257 1067
7,2	62257 1072
7,7	62257 1077
8,2	62257 1082
8,7	62257 1087
9,2	62257 1092
9,7	62257 1097
10,2	62257 1102
10,7	62257 1107
11,2	62257 1112
11,7	62257 1117
12,2	62257 1122
12,7	62257 1127
13,2	62257 1132
13,7	62257 1137
14,2	62257 1142
14,7	62257 1147
15,2	62257 1152
15,7	62257 1157
16,2	62257 1162
16,7	62257 1167
17,2	62257 1172
17,7	62257 1177
18,2	62257 1182
18,7	62257 1187
19,2	62257 1192
19,7	62257 1197
20,2	62257 1202
20,7	62257 1207
21,2	62257 1212
21,7	62257 1217
22,2	62257 1222
22,7	62257 1227

3,2	64203 1032
3,7	64203 1037
4,2	64203 1042
4,7	64203 1047
5,2	64203 1052
5,7	64203 1057
6,2	64203 1062
6,7	64203 1067
7,2	64203 1072
7,7	64203 1077
8,2	64203 1082
8,7	64203 1087
9,2	64203 1092
9,7	64203 1097
10,2	64203 1102
10,7	64203 1107
11,2	64203 1112
11,7	64203 1117
12,2	64203 1122
12,7	64203 1127
13,2	64203 1132
13,7	64203 1137
14,2	64203 1142
14,7	64203 1147
15,2	64203 1152
15,7	64203 1157
16,2	64203 1162
16,7	64203 1167
17,2	64203 1172
17,7	64203 1177
18,2	64203 1182
18,7	64203 1187
19,2	64203 1192
19,7	64203 1197
20,2	64203 1202
20,7	64203 1207
21,2	64203 1212
21,7	64203 1217
22,2	64203 1222
22,7	64203 1227

23,2	64203 1232
23,7	64203 1237
24,2	64203 1242
24,7	64203 1247
25,2	64203 1252
25,7	64203 1257
26,2	64203 1262
26,7	64203 1267
27,2	64203 1272
27,7	64203 1277
28,2	64203 1282
28,7	64203 1287
29,2	64203 1292
29,7	64203 1297
30,2	64203 1302
30,7	64203 1307

Rundstempel
round punch
poinçon rond

Nr. 57*



Artikel-Nr.	
23,0	62057 1230
24,0	62057 1240
25,0	62057 1250
30,0	62057 1300

Stempelkeil
taper pin
clavette de poinçon

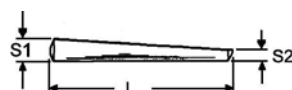

Artikel-Nr.
40610 540 81 02M

D Ø	S1	S2	L
5	4,4	3,2	40

*nur für
*only for
*uniquement pour

Peddy & Peddicat 275 H



Peddinghaus

Peddinghaus Anlagen & Maschinen GmbH

Peddinghaus Anlagen & Maschinen GmbH
 Hasslinghauser Str. 156 • D-58285 Gevelsberg
 Tel. +49 (0) 2332 / 6646-21/22/23
 Fax +49 (0) 2332 / 6646-46
 teile-pam@peddy.de • www.peddy.de

Peddy • Peddicat 275H • 21/16 • 36 RP 10

Vierkantstempel square punch poinçon carré	Vierkantstempel square punch poinçon carré	Vierkantmatrize square die matrice carrée	Vierkantmatrize square die matrice carrée	Schlüssellochstempel, quer keyhole punch, transverse poinçon pour canon européen
Nr. 55	Nr. 56	Nr. 57	Nr. 3*	Nr. 57*
Artikel-Nr.	Artikel-Nr.	Artikel-Nr.	Artikel-Nr.	Artikel-Nr.
4,0 62055 2040 5,0 62055 2050 6,0 62055 2060 7,0 62055 2070 8,0 62055 2080 9,0 62055 2090 10,0 62055 2100	11,0 62056 2110 12,0 62056 2120 13,0 62056 2130 14,0 62056 2140 15,0 62056 2150	4,2 62257 2042 4,7 62257 2047 5,2 62257 2052 5,7 62257 2057 6,2 62257 2062 6,7 62257 2067 7,2 62257 2072 7,7 62257 2077 8,2 62257 2082 8,7 62257 2087 9,2 62257 2092 9,7 62257 2097 10,2 62257 2102 10,7 62257 2107 11,2 62257 2112 11,7 62257 2117 12,2 62257 2122 12,7 62257 2127 13,2 62257 2132 13,7 62257 2137 14,2 62257 2142 14,7 62257 2147 15,2 62257 2152 15,7 62257 2157	4,2 64203 2042 4,7 64203 2047 5,2 64203 2052 5,7 64203 2057 6,2 64203 2062 6,7 64203 2067 7,2 64203 2072 7,7 64203 2077 8,2 64203 2082 8,7 64203 2087 9,2 64203 2092 9,7 64203 2097 10,2 64203 2102 10,7 64203 2107 11,2 64203 2112 11,7 64203 2117 12,2 64203 2122 12,7 64203 2127 13,2 64203 2132 13,7 64203 2137 14,2 64203 2142 14,7 64203 2147 15,2 64203 2152 15,7 64203 2157	34 × Ø 17,5 × 10,5 62057 17 001 Schlüssellochmatrize, quer keyhole die, transverse matrice pour canon européen Nr. 3* Artikel-Nr. 34,2 × Ø 17,7 × 10,7 65203 17 001

Stempelkeil
taper pin
clavette de poinçon

Artikel-Nr.
40610 540 81 02M

D Ø	S1	S2	L
5	4,4	3,2	40

*nur für
 *only for
 *uniquement pour

Peddy & Peddicat 275 H

Peddy • Peddicat 275H • 21/16 • 36 RP 10

Langlochstempel oblong punch poinçon oblong	Langlochmatrize oblong die matrice oblongue	Langlochmatrize oblong die matrice oblongue	Langlochstempel oblong punch poinçon oblong	Langlochmatrize oblong die matrice oblongue
Nr. 55	Nr. 57	Nr. 3*	Nr. 57*	Nr. 3*
Artikel-Nr.	Artikel-Nr.	Artikel-Nr.	Artikel-Nr.	Artikel-Nr.
5,0×10,0 62055 3050100 5,5×14,0 62055 3055140 6,5×12,0 62055 3065120 7,5×14,0 62055 3075140	5,2×10,2 62257 3052102 5,7×10,7 62257 3057107 5,7×14,2 62257 3057142 6,2×14,7 62257 3062147 6,7×12,2 62257 3067122 7,2×12,7 62257 3072127 7,7×14,2 62257 3077142 8,2×14,7 62257 3082147	5,2×10,2 64203 3052102 5,7×10,7 64203 3057107 5,7×14,2 64203 3057142 6,2×14,7 64203 3062147 6,7×12,2 64203 3067122 7,2×12,7 64203 3072127 7,7×14,2 64203 3077142 8,2×14,7 64203 3082147	6,5×26,0 62057 3065260 7,5×26,0 62057 3075260 9,0×26,0 62057 3090260 9,0×30,0 62057 3090300 10,0×26,0 62057 3100260 10,0×30,0 62057 3100300 11,0×26,0 62057 3110260 11,0×30,0 62057 3110300 12,0×24,0 62057 3120240 12,0×30,0 62057 3120300 13,0×26,0 62057 3130260 13,0×30,0 62057 3130300 14,0×28,0 62057 3140280	6,7×26,2 64203 3067262 7,2×26,7 64203 3072267 7,7×26,2 64203 3077262 8,2×26,7 64203 3082267 9,2×26,2 64203 3092262 9,7×26,7 64203 3097267 9,2×30,2 64203 3092302 9,7×30,7 64203 3097307 10,2×26,2 64203 3102262 10,7×26,7 64203 3107267 10,2×30,2 64203 3102302 10,7×30,7 64203 3107307 11,2×26,2 64203 3112262 11,7×26,7 64203 3117267 11,2×30,2 64203 3112302 11,7×30,7 64203 3117307 12,2×24,2 64203 3122242 12,7×24,7 64203 3127247 12,2×30,2 64203 3122302 12,7×30,7 64203 3127307 13,2×26,2 64203 3132262 13,7×26,7 64203 3137267 13,2×30,2 64203 3132302 13,7×30,7 64203 3137307 14,2×28,2 64203 3142282 14,7×28,7 64203 3147287
Langlochstempel oblong punch poinçon oblong				
Nr. 56				
Artikel-Nr.				
6,5×18,0 62056 3065180 7,5×21,0 65056 3075210 9,0×18,0 62056 3090180 10,0×20,0 62056 3100200 11,0×22,0 62056 3110220 12,0×20,0 62056 3120200	6,7×18,2 62257 3067182 7,2×18,7 62257 3072187 7,7×21,2 62257 3077212 8,2×21,7 62257 3082217 9,2×18,2 62257 3092182 9,7×18,7 62257 3097187 10,2×20,2 62257 3102202 10,7×20,7 62257 3107207 11,2×22,2 62257 3112222 11,7×22,7 62257 3117227 12,2×20,2 62257 3122202 12,7×20,7 62257 3127207	6,7×18,2 64203 3067182 7,2×18,7 64203 3072187 7,7×21,2 64203 3077212 8,2×21,7 64203 3082217 9,2×18,2 64203 3092182 9,7×18,7 64203 3097187 10,2×20,2 64203 3102202 10,7×20,7 64203 3107207 11,2×22,2 64203 3112222 11,7×22,7 64203 3117227		

Stempelkeil
taper pin
clavette de poinçon

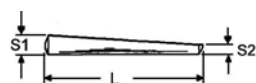

Artikel-Nr.
40610 540 81 02M

D Ø	S1	S2	L
5	4,4	3,2	40

*nur für
*only for
*uniquement pour

Peddy & Peddicat 275 H



Peddinghaus

Peddinghaus Anlagen & Maschinen GmbH

Peddinghaus Anlagen & Maschinen GmbH
Hasslinghauser Str. 156 • D-58285 Gevelsberg
Tel. +49 (0) 2332 / 6646-21/22/23
Fax +49 (0) 2332 / 6646-46
teile-pam@peddy.de • www.peddy.de

Stempel und Matrizen • Punches and Dies • Poinçons et matrices



für Peddinghaus-Handlochstanzen
to suit Peddinghaus hand-lever punching machines
pour les poinçonneuses manuelles Peddinghaus

21/8 P • 21/8
21/12
34 BR 6 P • 34 BR 6
35 BR 6
36 RP 8
Duplex 27/150 • 27/250

21/8P • 21/8 • 21/12 • 34 BR 6P • 34 BR 6 • 35 BR 6 • 36 RP 8

Zum Einsatz in der Normal-Stanzvorrichtung
 for use in the standard punching attachment
 pour utilisation dans le dispositif de poinçonnage standard

Rundstempel round punch poinçon rond	Rundmatrize round die matrice ronde	Rundstempel round punch poinçon rond	Rundmatrize round die matrice ronde
Nr. 51	Nr. 51	Nr. 52	Nr. 52
Artikel-Nr.	Artikel-Nr.	Artikel-Nr.	Artikel-Nr.
3,0 62051 1030	3,2 62251 1032	11,0 62052 1110	10,7 62252 1107
3,5 62051 1035	3,7 62251 1037	12,0 62052 1120	11,2 62252 1112
4,0 62051 1040	4,2 62251 1042	13,0 62052 1130	11,7 62252 1117
4,5 62051 1045	4,7 62251 1047	14,0 62052 1140	12,2 62252 1122
5,0 62051 1050	5,2 62251 1052	15,0 62052 1150	12,7 62252 1127
5,5 62051 1055	5,7 62251 1057	16,0 62052 1160	13,2 62252 1132
6,0 62051 1060	6,2 62251 1062	17,0 62052 1170	14,2 62252 1142
6,5 62051 1065	6,7 62251 1067	18,0 62052 1180	15,2 62252 1152
7,0 62051 1070	7,2 62251 1072		16,2 62252 1162
7,5 62051 1075	7,7 62251 1077		17,2 62252 1172
8,0 62051 1080	8,2 62251 1082		18,2 62252 1182
8,5 62051 1085	8,7 62251 1087		
9,0 62051 1090	9,2 62251 1092		
9,5 62051 1095	9,7 62251 1097		
10,0 62051 1100	10,2 62251 1102		

Vierkantstempel square punch poinçon carré	Vierkantmatrize square die matrice carrée	Vierkantstempel square punch poinçon carré	Vierkantmatrize square die matrice carrée
Nr. 51	Nr. 51	Nr. 52	Nr. 52
Artikel-Nr.	Artikel-Nr.	Artikel-Nr.	Artikel-Nr.
4,0 62051 2040	4,2 62251 2042	8,0 62052 2080	8,2 62252 2082
5,0 62051 2050	5,2 62251 2052	9,0 62052 2090	9,2 62252 2092
6,0 62051 2060	6,2 62251 2062	10,0 62052 2100	10,2 62252 2102
7,0 62051 2070	7,2 62251 2072	11,0 62052 2110	11,2 62252 2112
		12,0 62052 2120	12,2 62252 2122

Stempelkeil
 taper pin
 clavette de poinçon
 Artikel-Nr.
 21000 198 504

21 / 8 P
 34 BR 6 P

Gewindestift
 grub screw
 vis sans tête
 Artikel-Nr.
 7000913 08012



21/8P • 21/8 • 21/12 • 34 BR 6P • 34 BR 6 • 35 BR 6 • 36 RP 8

Zum Einsatz in
 Sonder-Stanzvorrichtung \varnothing 19 – 45 mm
 bestehend aus

- Stempelkeil
- Abstreifersatz
- Matrizenhalter komplett







for use in oversize punching attachment
 \varnothing 19 up to \varnothing 45 mm
 consisting of

- taper pin
- stripper assembly
- die holder complete

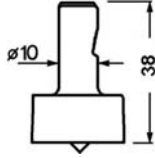
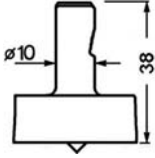
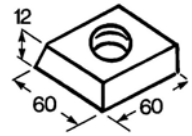
pour dispositif de poinçonnage
 grand diamètre de 19 à 45 mm \varnothing
 comportant

- clavette de poinçon
- dévêtitseur, jeu
- porte-matrice complet

Sonder-Stanzvorrichtung \varnothing 19 – 45, komplett oversize punching attachment, complete dispositif de poinçonnage grand diamètre complet	Modell	Artikel-Nr. • part no. • no. de réf.
	21 / 8 P • 34 BR 6 P	21010 540 10 00 P
	21 / 8 • 34 BR 6 • 35 BR 6	21010 540 10 00
	21 / 12 • 36 RP 8	21001 540 10 00

	Stempel punch poinçon		Stempel punch poinçon		Matrize die matrice	
	Nr. 53		Nr. 54		Nr. 53	
von - bis mm from - up to mm de - à mm	\varnothing 18,5 - 30	\varnothing 18,5 - 30	\varnothing 30,5 - 45	\varnothing 30,5 - 45	\varnothing 18,7 – 45,2	\varnothing 18,7 – 45,2
	Rundstempel round punch poinçon rond 62053 1		Rundstempel round punch poinçon rond 62054 1		Rundmatrize round die matrice ronde 62253 1	
	Vierkantstempel square punch poinçon carré S = 13 - 29 62053 2		Vierkantstempel square punch poinçon carré S = 21,5 - 32 62054 2		Vierkantmatrize square die matrice carrée S = 13,2 – 32,2 62253 2	
	Langlochstempel längs oblong punch longitudinal poinçon oblong sens longitudinal 62053 3	Langlochstempel quer oblong punch transverse poinçon oblong sens transversal 62053 4	Langlochstempel längs oblong punch longitudinal poinçon oblong sens longitudinal 62054 3	Langlochstempel quer oblong punch transverse poinçon oblong sens transversal 62054 4	Langlochmatrize längs oblong die longitudinal matrice oblongue sens longitudinal 62253 3	Langlochmatrize quer oblong die transverse matrice oblongue sens transversal 62253 4
	Rechteckstempel längs rectangular punch longitudinal poinçon rectang. sens longitudinal 62053 5	Rechteckstempel quer rectangular punch transverse poinçon rectang. sens transversal 62053 6	Rechteckstempel längs rectangular punch longitudinal poinçon rectang. sens longitudinal 62054 5	Rechteckstempel quer rectangular punch transverse poinçon rectang. sens transversal 62054 6	Rechteckmatrize längs rectangular die longitudinal matrice rectang. sens longitudinal 62253 5	Rechteckmatrize quer rectangular die transverse matrice rectang. sens transversal 62253 6
	-	-	-	Schlüsselloch- stempel key hole punch poinçon p. canon	-	Schlüsselloch- matrize key hole die matrice p. canon

Modell Duplex

27 / 150

Rundstempel
 round punch
 poinçon rond
Nr. 74

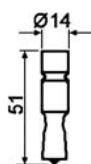

Rundmatrize
 round die
 matrice ronde
Nr. 74



27 / 250

Rundstempel
 round punch
 poinçon rond
Nr. 75

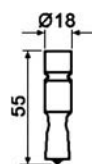

Rundmatrize
 round die
 matrice ronde
Nr. 75

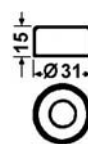

	Artikel-Nr.		Artikel-Nr.		Artikel-Nr.		Artikel-Nr.
	6,0 62074 1060		6,2 62274 1062		6,0 62075 1060		6,2 62275 1062
	7,0 62074 1070		6,7 62274 1067		7,0 62075 1070		6,7 62275 1067
	8,0 62074 1080		7,2 62274 1072		8,0 62075 1080		7,2 62275 1072
	9,0 62074 1090		7,7 62274 1077		9,0 62075 1090		7,7 62275 1077
	10,0 62074 1100		8,2 62274 1082		10,0 62075 1100		8,2 62275 1082
	11,0 62074 1110		8,7 62274 1087		11,0 62075 1110		8,7 62275 1087
	12,0 62074 1120		9,2 62274 1092		12,0 62075 1120		9,2 62275 1092
	13,0 62074 1130		9,7 62274 1097		13,0 62075 1130		9,7 62275 1097
			10,2 62274 1102		14,0 62075 1140		10,2 62275 1102
			10,7 62274 1107		15,0 62075 1150		10,7 62275 1107
			11,2 62274 1112		16,0 62075 1160		11,2 62275 1112
			11,7 62274 1117		17,0 62075 1170		11,7 62275 1117
			12,2 62274 1122				12,2 62275 1122
			12,7 62274 1127				12,7 62275 1127
			13,2 62274 1132				13,2 62275 1132
			13,7 62274 1137				13,7 62275 1137
							14,2 62275 1142
							14,7 62275 1147
							15,2 62275 1152
							15,7 62275 1157
							16,2 62275 1162
							16,7 62275 1167
							17,2 62275 1172
							17,7 62275 1177

Stempel-Schnellwechsellvorrichtung bis 31 mm Ø

Quick-change punching attachment up to 31 mm Ø

Dispositif de serrage rapide du poinçon jusqu'à 31 mm Ø

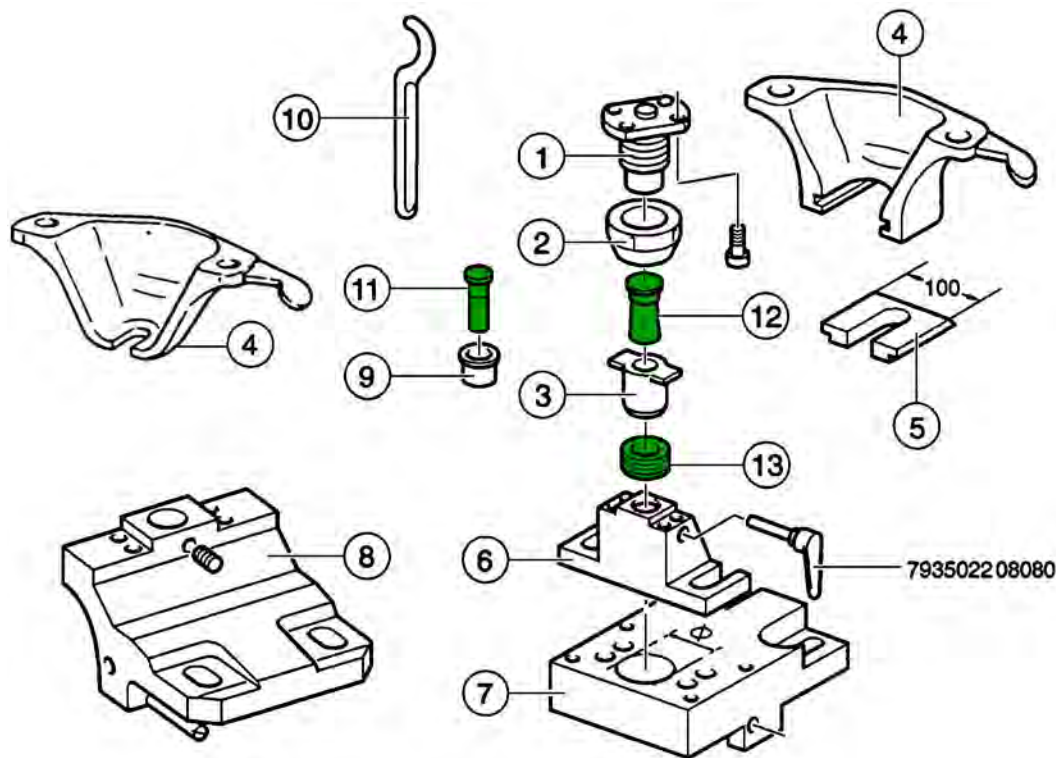

Pos.	Bezeichnung	Description	Description
1	Schnellwechsel-Stempelhalter	quick-change punch holder	porte-poinçon à serrage rapide
2	Schnellspannmutter	quick-change locking nut	écrou de fixation
3	Schnellspanneinsatz	quick-change punch sleeve	douille de serrage rapide
4	Abstreiferplattenaufnahme	stripper plate holder	dévêtisseur à plaque
5	Abstreiferplatte Ø34	stripper plate Ø34	plaque de dévêtisseur Ø 34
6	Matrizenhalter Nr. 3	die holder no. 3	porte-matrice no. 3
7	Stanzentisch Ø 97	flat die bolster Ø 97	table de poinçonnage plate Ø 97
7•1	Stanzentisch Ø 72	flat die bolster Ø 72	table de poinçonnage plate Ø 72
8	Universal-Stanzsattel für Matrize Nr. 3	universal die block for die no. 3	porte-matrice universel pour matrice no. 3
9	Reduzierhülse 2/5	punch reducing sleeve 2/5	réducteur 2/5
10	Hakenschlüssel 80/90	hook spanner 80/90	clé de serrage 80/90
11	Stempel Nr. 2 bis Ø 19,0 mm	punch no. 2 up to Ø 19.0 mm	poinçon no. 2 jusqu'à Ø 19,0 mm
12	Stempel Nr. 5 bis Ø 32,0 mm	punch no. 5 up to Ø 32.0 mm	poinçon no. 5 jusqu'à Ø 32,0 mm
13	Matrize Nr. 3 bis Ø 33,2 mm	die no. 3 up to Ø 33.2 mm	matrice no. 3 jusqu'à Ø 33,2 mm



Elemente der Stempel-Schnellwechsellvorrichtung

Elements of the quick-change punching attachment

Éléments du dispositif de changement rapide du poinçon

Schnellwechsel-Stempelhalter • quick-change punch holder • porte-poinçon à serrage rapide

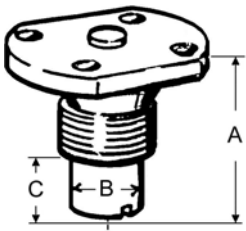

A	B	C	Artikel-Nr.	Verwendung
62	37	22	40615 560 01 00	Grüne Serie (ab 1993)
100	37	47	44081 199 990	Grüne Serie (bis 1993)
71	32	28	44001 199 990	Rote Serie
109	45	50	44161 199 990	Blaue Serie (210 Super 25)
50,3	45	13,3	44600 199 990	Blaue Serie (Peddimax No 1 + Hydraulic 1250)

Schnellwechsellmutter • quick-change locking nut • écrou de serrage rapide

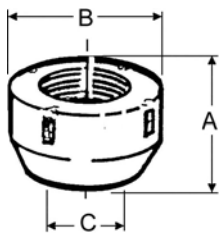

A	B	C	Artikel-Nr.	Verwendung
45	85	52,5	44081 198 991	Grüne Serie
38	70	45,5	44001 198 991	Rote Serie
55	100	60,5	44161 198 991	Blaue Serie (210 Super 25)
41	85	52,5	44600 198 991	Blaue Serie (Peddimax No 1 + Hydraulic 1250)

Schnellspanneinsatz • quick-change punch sleeve • douille de serrage rapide

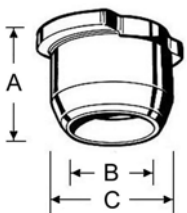

A	B	C	Artikel-Nr.	Verwendung
35	32,2	52	42030 621 91 02	Grüne Serie (ab 1993)
60	32,2	52	44081 198 992	Grüne Serie (bis 1993)
44	27,1	45	44001 198 992	Rote Serie
62	39,7	60	44161 198 992	Blaue Serie (210 Super 25)
24	39,7	52	44600 198 992	Blaue Serie (Peddimax No 1 + Hydraulic 1250)

Elemente der Stanzvorrichtungen • Elements of the punching attachments • Éléments des dispositifs de poinçonnage

Reduzierhülsen • reducing sleeves • douilles de réduction

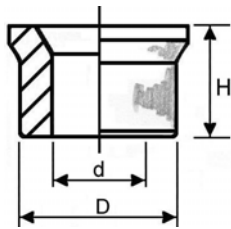

d	D	H	Artikel-Nr.	für Stempel Nr. for punch no. • pour poinçon no.
14,5	26,4	24,5	44001 198 503	1 / 4
19,4	31,0	22,0	44081 198 503	2 / 5
26,5	39,5	29,0	44161 198 503	3 / 6
26,5	58,5	23,0	44001 198 813	3 / 7
39,7	58,5	23,0	44001 198 814	6 / 7
26,5	90,0	23,0	44001 198 833 3	3 / 11
39,7	90,0	23,0	44001 198 833 2	6 / 11
58,7	90,0	23,0	44001 198 833 1	7 / 11

Verlängerungsreduzierhülsen • prolongation reducing sleeves • douilles de réduction de rallonge

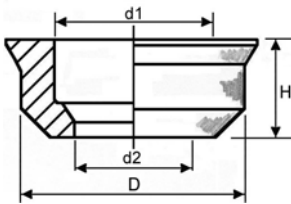

d1	d2	D	H	Artikel-Nr.	für Stempel Nr. for punch no. • pour poinçon no.
40	26,6	58,5	38	44001 198 813 3	4 / 7
40	31,7	58,5	25	40778 568 07 01	5 / 7
40	26,6	90	38	44001 198 833 4	4 / 11
40	31,7	90	25	44081 198 833 1	5 / 11

Druckstücke • filler pieces • rondelles de pression

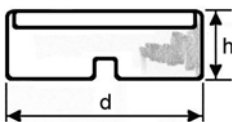

d	h	Artikel-Nr.	für Stempel Nr. for punch no. • pour poinçon no.
39	22	44001 198 814 3	4 / 7 + 11
39	15	40778 568 07 02	5 / 7 + 11

Passfedern DIN 6885 (Verdrehungsschutz) • parallel keys • clavettes de poinçon

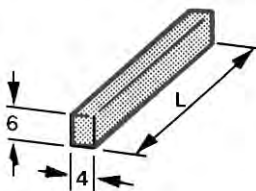

L	Stück piece pièce Artikel-Nr.	Satz = 5 Stück set = 5 pieces jeu = 5 pièces Artikel-Nr.	Satz = 10 Stück set = 10 pieces jeu = 10 pièces Artikel-Nr.	für Stempel Nr. for punch no. • pour poinçon no.
17	65100 9 90170	65100 9 80170	65100 9 70170	1
23,5	65100 9 90235	65100 9 80235	65100 9 70235	2
28,5	65100 9 90285	65100 9 80285	65100 9 70285	3 + 4
33,5	65100 9 90335	65100 9 80335	65100 9 70335	5
41,5	65100 9 90415	65100 9 80415	65100 9 70415	6
63	65100 9 90630	65100 9 80630	65100 9 70630	7
92	65100 9 90920	65100 9 80920	65100 9 70920	11

Elemente der Stanzvorrichtungen • Elements of the punching attachments • Éléments des dispositifs de poinçonnage

Peddimax No. 1 Hydraulic 1250

Für die Weiterverwendung der Stempel – **Grüne Serie** –
 in der Normal-Stanzvorrichtung (**Blaue Serie**) bei Peddimax No. 1 und Hydraulic 1250

For using the punches of the **Green Series**
 in the standard punching attachment (**Blue Series**) of Peddimax No 1 and Hydraulic 1250

Pour utiliser les poinçons de la **série verte**
 dans le dispositif de poinçonnage standard (**série bleue**) des modèles Peddimax No 1 et Hydraulic 1250

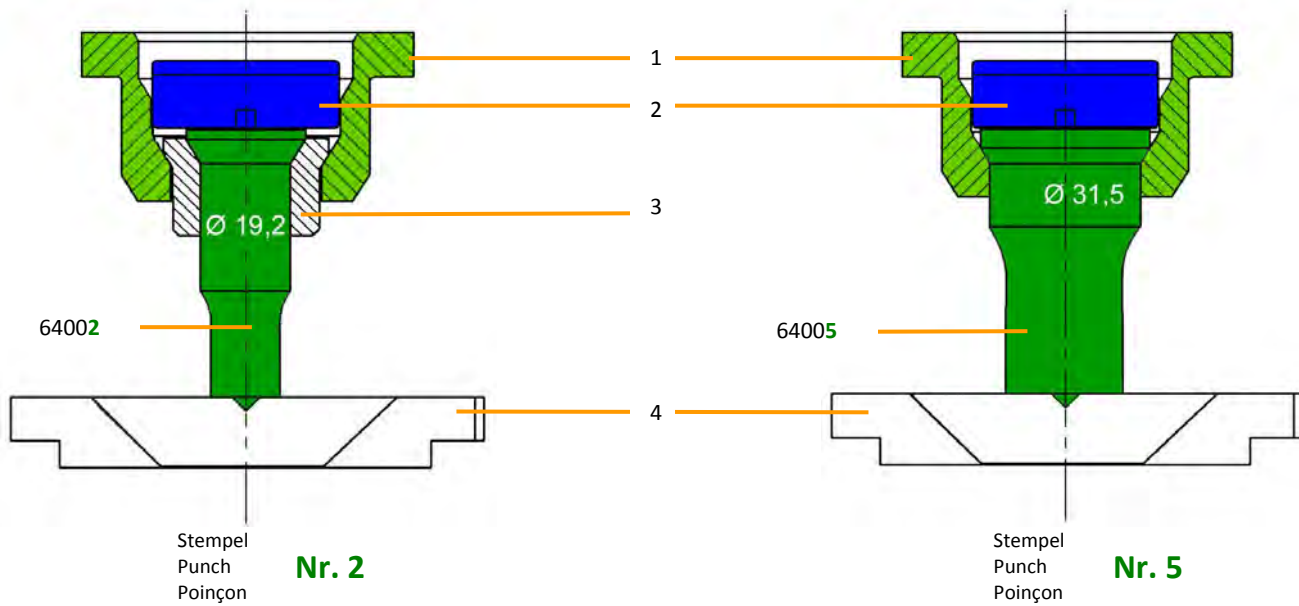

Pos.	Bezeichnung	Description	Description	Artikel-Nr.
1	Schnellspanneinsatz Stempel Nr. 5	quick-change punch sleeve for punch no. 5	douille de serrage rapide pour poinçon no. 5	44600 198 993
2	Druckstück 5 / 7 + 11	filler piece 5 / 7 + 11	rondelle de pression 5 / 7 + 11	40778 568 07 02
3	Reduzierhülse 2 / 5	reducing sleeve 2 / 5	réducteur 2 / 5	44081 198 503
4	Abstreiferplatte Ø 34 mm	stripper plate Ø 34mm	plaque de dévêtitseur Ø 34 mm	40613 540 12 12 L

Elemente der Stanzvorrichtungen • Elements of the punching attachments • Éléments des dispositifs de poinçonnage

Zur Sonder-Stanzvorrichtung bis

to suit the oversize punching attachment up to
 pour dispositif de poinçonnage jusqu'à

58 mm Ø

A



Stempelhalter • punch holder • porte-poinçon

Gesamthöhe* overall height* hauteur totale*	Gewindedurchmesser thread diameter diamètre du filetage	Artikel-Nr. part no. no. de réf.
50 mm	69,8 mm Ø	42200 540 12 02

für alle Maschinen der heutigen Generation
 suitable for all machines of our current range
 pour toutes les machines de notre gamme actuelle

Ersatz für • substitutes
 Artikel-Nr.
 44001 199 811

B



Stempelhalter • punch holder • porte-poinçon

Gesamthöhe* overall height* hauteur totale*	Gewindedurchmesser thread diameter diamètre du filetage	Artikel-Nr. part no. no. de réf.
94 mm	69,8 mm Ø	44081 198 811

für ältere Maschinengenerationen
 suitable for older machine generations
 pour machines des anciennes gammes

210 • 210 Super
 Peddimaster
 Forax

Zur Sonder-Stanzvorrichtung bis

to suit the oversize punching attachment up to
 pour dispositif de poinçonnage jusqu'à

90 mm Ø

C



Stempelhalter • punch holder • porte-poinçon

Gesamthöhe* overall height* hauteur totale*	Gewindedurchmesser thread diameter diamètre du filetage	Artikel-Nr. part no. no. de réf.
50 mm	98 mm Ø	42215 540 14 01

D

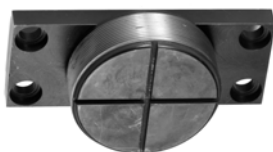

Stempelhalter • punch holder • porte-poinçon

Gesamthöhe* overall height* hauteur totale*	Gewindedurchmesser thread diameter diamètre du filetage	Artikel-Nr. part no. no. de réf.
50 mm	98 mm Ø	44001 199 831

E



Stempelhalter • punch holder • porte-poinçon

Gesamthöhe* overall height* hauteur totale*	Gewindedurchmesser thread diameter diamètre du filetage	Artikel-Nr. part no. no. de réf.
94 mm	98 mm Ø	44081 198 831

*Gesamthöhe gemessen ohne Zentrierzapfen 20Ø x 4 • overall height without centering pin 20Ø x 4 • hauteur totale sans goujon de centrage 20Ø x 4

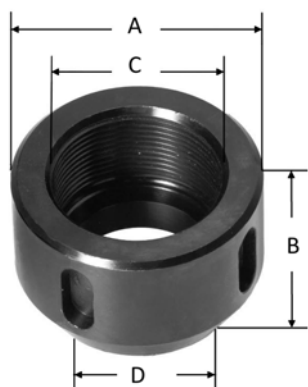

Zur Normal-Stanzvorrichtung (alte Version)

to suit the old-style standard punching attachment
 pour dispositif de poinçonnage standard (ancien système)

Stempelmutter

punch locking nut
 écrou de fixation

A	B	C	D	Artikel-Nr.
52	30	31	27,1	44001 198 224
70	45	45	32,2	44081 198 224 L
70	45	45	39,7	44161 198 224

Zur Sonder-Stanzvorrichtung bis 58 mm Ø

to suit the oversize punching attachment up to 58 mm Ø
 pour dispositif de poinçonnage grand diamètre jusqu'à 58 mm Ø

Stempelmutter

punch locking nut
 écrou de fixation

A	B	C	D	Artikel-Nr.
90	38	67,5	58,7	44001 198 812

Zur Sonder-Stanzvorrichtung bis 90 mm Ø

to suit the oversize punching attachment up to 90 mm Ø
 pour dispositif de poinçonnage grand diamètre jusqu'à 90 mm Ø

Stempelmutter

punch locking nut
 écrou de fixation

A	B	C	D	Artikel-Nr.
120	38	95,4	90,2	44001 198 832

Hakenschlüssel DIN 1810A

hook spanner
 clé de serrage

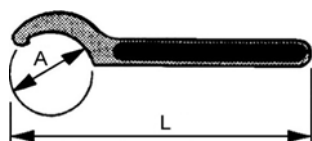

A	L ~	Artikel-Nr.
Ø 52 - 55	206	7001810 52055
Ø 68 - 75	244	7001810 68075
Ø 80 - 90	280	7001810 80090
Ø 120 - 130	340	7001810 96050



Elemente der Stanzvorrichtungen • Elements of the punching attachments • Éléments des dispositifs de poinçonnage

Reduziereinsatz für Matrizen

Die reducing socket

Bague de réduction pour matrices

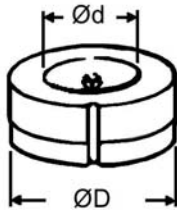

$\frac{\text{Ø d}}{\text{Ø D}}$	$\frac{\text{Ø 35}}{\text{Ø 35}}$	$\frac{\text{Ø 46,04}}{\text{Ø 46,04}}$	$\frac{\text{Ø 50,8}}{\text{Ø 50,8}}$	$\frac{\text{Ø 63,5}}{\text{Ø 63,5}}$	$\frac{\text{Ø 90}}{\text{Ø 90}}$
Matrize die • matrice	Nr. 57 - Peddy	Nr. 2	Nr. 3	Nr. 4	Nr. 6
$\frac{\text{Ø 50,8}}{\text{Ø 50,8}}$ Nr. 3	Reduziereinsatz Peddy / 3F reducing socket bague de réduction 40610 199 957				
$\frac{\text{Ø 63,5}}{\text{Ø 63,5}}$ Nr. 4	Reduziereinsatz 2 / 4 reducing socket bague de réduction 44041 199 807		Reduziereinsatz 3 / 4 reducing socket bague de réduction 44081 199 807		
$\frac{\text{Ø 90}}{\text{Ø 90}}$ Nr. 6	Reduziereinsatz 2 / 6 reducing socket bague de réduction 44001 199 817		Reduziereinsatz 3 / 6 reducing socket bague de réduction 44081 199 817		Reduziereinsatz 4 / 6 reducing socket bague de réduction 44001 199 818
$\frac{\text{Ø 140}}{\text{Ø 140}}$ Nr. 20	Reduziereinsatz 2 / 20 reducing socket bague de réduction 44001 199 837 3		Reduziereinsatz 3 / 20 reducing socket bague de réduction 44081 199 837 3		Reduziereinsatz 4 / 20 reducing socket bague de réduction 44001 199 837 2
					Reduziereinsatz 6 / 20 reducing socket bague de réduction 44001 199 837 1

Zur Normal-Stanzvorrichtung (Stempel-Schnellwechsellvorrichtung)

to suit the standard punching attachment (quick-change punching attachment)
 pour dispositif de poinçonnage standard (à changement rapide du poinçon)

A



Matrizenhalter • die holder • porte-matrice

Matrizen-Außen-Ø die o.d. dia. ext. matrice	Höhe height hauteur	Lochmittenabstand hole center distance entr'axe des trous	Artikel-Nr. part no. no. de réf.
46,04	50	165	44001 199 802
50,8	50	165	44001 540 16 02
46,04	73	165	44041 199 802
50,8	73	165	44041 540 16 02



B



Matrizenhalter • die holder • porte-matrice

Matrizen-Außen-Ø die o.d. dia. ext. matrice	Höhe height hauteur	Lochmittenabstand hole center distance entr'axe des trous	Artikel-Nr. part no. no. de réf.
50,8	72	165	44233 553 07 00
46,04	72	165	42017 620 14 01



C



Matrizenhalter • die holder • porte-matrice

Matrizen-Außen-Ø die o.d. dia. ext. matrice	Höhe height hauteur	Lochmittenabstand hole center distance entr'axe des trous	Artikel-Nr. part no. no. de réf.
50,8	130	165	44081 199 802
46,04	130	165	44121 626 60 03
63,5	123	165	42220 553 07 00

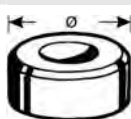

Elemente der Stanzvorrichtungen • Elements of the punching attachments • Éléments des dispositifs de poinçonnage

Zur Sonder-Stanzvorrichtung (mit Reduziereinsätzen)

to suit the oversize punching attachments (with reducing sockets)
 pour dispositifs de poinçonnage grand diamètre (avec réducteurs)

58 + 90 mm Ø

**SV
58**



Matrizenhalter • die holder • porte-matrice

Matrizen-Außen-Ø die o.d. dia. ext. matrice	Höhe height hauteur	Lochmittenabstand hole center distance entr'axe des trous	Artikel-Nr. part no. no. de réf.
90	42,8	165	44001 198 816
90	65,8	165	44041 199 816
90	122,8	165	44081 198 816

Auflagering • supporting ring • bague de support

90	12		44001 198 810
----	----	--	---------------

**SV
90**



Matrizenhalter • die holder • porte-matrice

Matrizen-Außen-Ø die o.d. dia. ext. matrice	Höhe height hauteur	Lochmittenabstand hole center distance entr'axe des trous	Artikel-Nr. part no. no. de réf.
140	42,8	178	44001 199 836
140	65,8	178	44041 198 836
140	119,8	178	44081 198 836

Auflagering • supporting ring • bague de support

140	12		44001 198 830
-----	----	--	---------------

Zur Sonder-Stanzvorrichtung (Version ohne Reduziereinsätze)

to suit the oversize punching attachments (version without reducing sockets)
 pour dispositifs de poinçonnage grand diamètre (version sans réducteurs)

65 + 90 mm Ø

Matrizenhalter
 die holder
 porte-matrice

Nr. 3

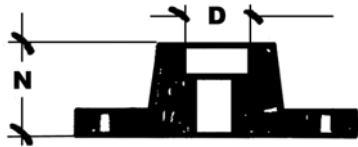

D	N	Artikel-Nr. part no. no. de réf.
50,8	72	44233 553 07 00

Matrizenhalter
 die holder
 porte-matrice

Nr. 4



D	N	Artikel-Nr. part no. no. de réf.
63,5	65,8	44233 555 01 00

Matrizenhalter
 die holder
 porte-matrice

Nr. 6

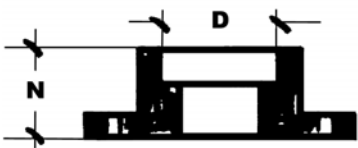

D	N	Artikel-Nr. part no. no. de réf.
90	65,8	44233 555 02 00

Matrizenhalter
 die holder
 porte-matrice

Nr. 20

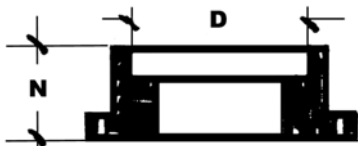

D	N	Artikel-Nr. part no. no. de réf.
140	65,8	44233 555 03 00

Zwischenplatte
 adapter plate
 plaque interm.

SV 65

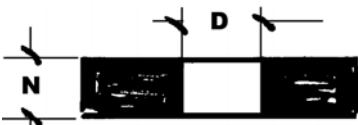

D	N	Artikel-Nr. part no. no. de réf.
72	56,9	42220 568 17 00

Zwischenplatte
 adapter plate
 plaque interm.

SV 90



D	N	Artikel-Nr. part no. no. de réf.
97	56,9	42220 570 17 00



Elemente der Stanzvorrichtungen • Elements of the punching attachments • Éléments des dispositifs de poinçonnage

Universal-Stanzsattel
 Universal die block
 Porte-matrice universel

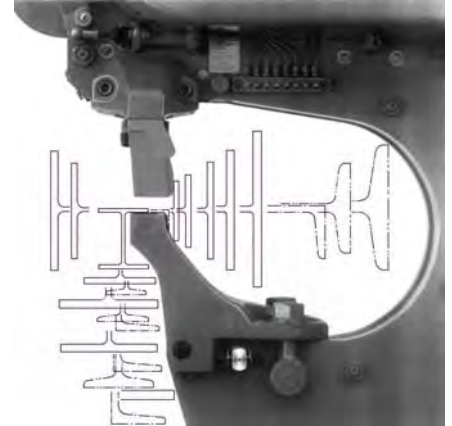
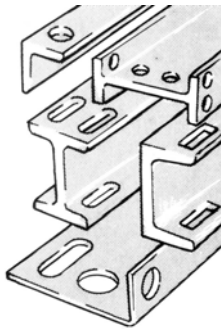

Universal-Stanzsattel für Matrize Nr. 3

universal die block
 for die no. 3

porte-matrice
 universel
 pour matrice no. 3

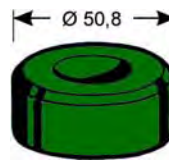

Universal-Stanzsattel für Matrize Nr. 2

universal die block
 for die no. 2

porte-matrice
 universel
 pour matrice no. 2

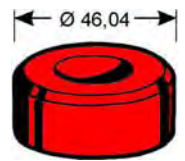

Modell

Peddimax

600 • 601 • 602	44225 552 06 00	44225 563 11 00
800 • 801 • 1002 • No. 1	44235 562 11 00	44235 563 11 00

Peddiworker

600	–	40625 551 06 00
800	–	40627 551 06 00
801 • 802 • No. 1	40627 552 06 00	
1000 G	40630 551 06 00	–

Peddimaster

28/40	–	44210 551 06 00
40/60 • 60/80	–	44220 551 06 00
60/100 • 80/110 • 800/1100	44230 552 06 00	44230 551 06 00
100/160 • 110/170 • 1100/1700	44240 551 06 00	–

Hydraulic

60 N	44230 552 06 00	44230 551 06 00
300 • 500	–	40625 551 06 00 L
301 • 501	42215 552 06 00	–
502	42225 562 11 00	–
800	42218 551 06 00	–
1000	42068 540 15 01	–
1000 N • 1400 N	42220 551 06 00	–
1001 • 1250	44235 562 11 00	–

210 Super

11	–	44001 199 228
13	44041 540 15 31	44041 199 228
16	44081 199 228	–
20	44121 199 228	–

Abstreifer • Strippers • Dêvêtisseurs

Peddibasic & Peddicat

Abstreiferplattenaufnahme

zur Normalstanzvorrichtung und zur Sonderstanzvorrichtung bis 58 Ø
 stripper plate holder to suit standard and oversize punching attachment up to 58 Ø
 dêvêtisseur à plaque pour disp. de poinçonnage standard et jusqu'à 58 Ø

Peddibasic No. 1	Pos.	A	Artikel-Nr.
Peddicat No. 1	1	100	40800 560 09 30

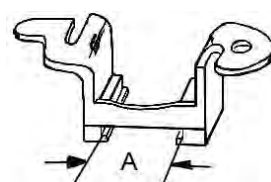

Peddicat 500	Pos.	A	Artikel-Nr.
	2	100	40790 123 01 50

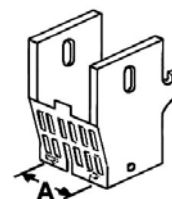

Peddicat	Pos.	A	B	C	Artikel-Nr.
380	3	100,2	154,5	166	40779 560 09 30
361	4	100,2	124,5	161	40778 560 09 30

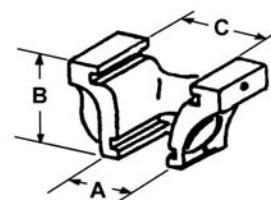

Abstreiferplatten zu Pos. 1 – 4:
 stripper plates to suit items 1 through 4:
 plaques de dêvêtisseur pour les postes 1 à 4 :

Ø	Artikel-Nr.
15 mm	40613 540 12 11
34 mm dünn	40613 540 12 12 L
34 mm dick*	40778 560 09 01*
42 mm	40613 540 12 13
52 mm	40613 540 12 14
69 mm	40613 540 12 15

*für Materialstärke bis 6 mm
 *for thin plate up to 6 mm thickness
 *pour tôle mince jusqu'à 6 mm d'épaisseur

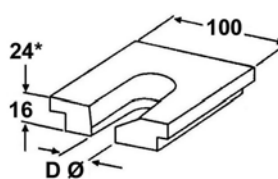

Peddicat 360	Pos.	A	B	C	Artikel-Nr.
zur Normal-Stanzvorrichtung to suit standard punching attachmt pour disp. de poinçonnage stand.	5	32	126	156	40776 540 05 00B
zur Sonderstanzvorrichtung 58 Ø to suit oversize punching att. 58 Ø pour dispositif grand diamètre 58 Ø	6	60	135	156	40777 540 12 20

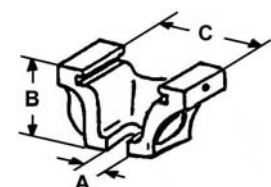

Peddicat 275	Pos.	Artikel-Nr.
	7	40775 541 01 00

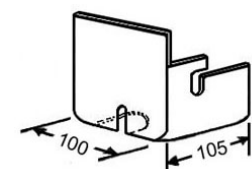

Elemente der Stanzvorrichtungen • Elements of the punching attachments • Éléments des dispositifs de poinçonnage

Abstreifer • Strippers • Dévêtisseurs

Peddiworker

Abstreiferplattenaufnahme

zur Normalstanzvorrichtung und zur Sonderstanzvorrichtung bis 58 Ø

stripper plate holder to suit standard punching attachment and oversize punching attachment up to 58 Ø

dévêtisseur à plaque pour dispositifs standard et grand diamètre jusqu'à 58 mm Ø

Peddiworker
400 • 600

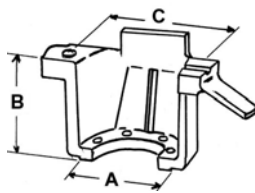

A	B	C	Artikel-Nr.
95	96,5	143	40625 551 05 00

Abstreiferplatten

stripper plates
plaques de dévêtisseur

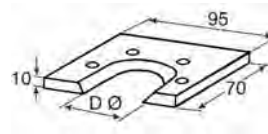

Ø	Artikel-Nr.
15	40622 540 12 11
32	40622 540 12 12
42	40622 540 12 13
52	40622 540 12 14
61	40622 540 12 15

Peddiworker
No. 1

500
501
502
800
801
802

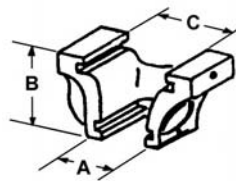

A	B	C	Artikel-Nr.
100,2	106,2	191	40613 540 05 00M

Abstreiferplatten

stripper plates
plaques de dévêtisseur

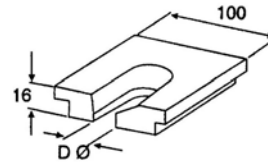

Ø	Artikel-Nr.
15	40613 540 12 11
34	40613 540 1212L
42	40613 540 12 13
52	40613 540 12 14
69	40613 540 12 15

Peddiworker
1000
1000 G

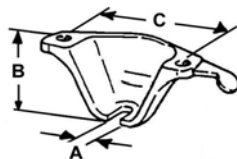

A	B	C	Artikel-Nr.
35	128	245,6	44081 551 05 00

Abstreifer zur Normalstanzvorrichtung

stripper to suit the standard punching attachment
dévêtisseur pour dispositif de poinçonnage standard

Abstreiferplattenaufnahme zu den Sonderstanzvorrichtungen

stripper plate holder to suit the oversize punching attachments

dévêtisseur à plaque pour les dispositifs de poinçonnage grand diamètre

Peddiworker
1000
1000 G

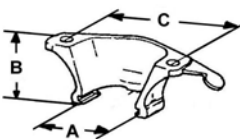

A	B	C	Artikel-Nr.
150,2	126,5	245,6	44081 199 840

Abstreiferplatten

stripper plates
plaques de dévêtisseur

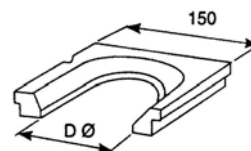

Ø	Artikel-Nr.
15	44001 198 840 1
30	44001 198 840 2
40	44001 198 840 3
50	44001 198 840 4
60	44001 198 840 5
75	44001 198 840 6
95	44001 198 840 7
105	44001 198 840 8

Abstreifer • Strippers • Dévêtisseurs

Peddimax

Abstreiferplattenaufnahme

zur Normalstanzvorrichtung und zur Sonderstanzvorrichtung bis 58 Ø

stripper plate holder to suit standard punching attachment and oversize punching attachment up to 58 Ø

dévêtisseur à plaque pour dispositifs standard et grand diamètre jusqu'à 58 mm Ø

Peddimax

No. 1

600
601
602
800
801
1002

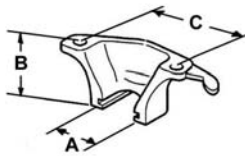

A	B	C	Artikel-Nr.
100,2	72	226	44233 560 09 30

Abstreiferplatten

stripper plates
plaques de dévêtisseur

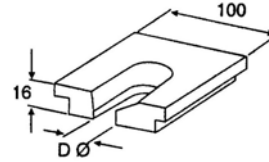

Ø	Artikel-Nr.
15	40613 540 12 11
34	40613 540 1212L
42	40613 540 12 13
52	40613 540 12 14
69	40613 540 12 15

Abstreiferplattenaufnahme zur Sonderstanzvorrichtung bis 90 Ø

stripper plate holder to suit oversize punching attachment up to 90 Ø

dévêtisseur à plaque pour dispositif de poinçonnage grand diamètre jusqu'à 90 Ø

Peddimax

No. 1

600
601
602
800
801
1002

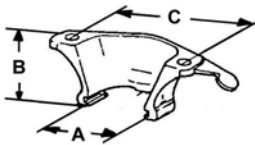

A	B	C	Artikel-Nr.
150,2	73,5	226	44230 199 840

Abstreiferplatten

stripper plates
plaques de dévêtisseur

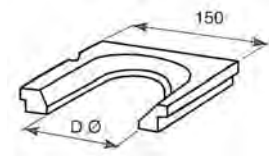

Ø	Artikel-Nr.
15	44001 198 840 1
30	44001 198 840 2
40	44001 198 840 3
50	44001 198 840 4
60	44001 198 840 5
75	44001 198 840 6
95	44001 198 840 7
105	44001 198 840 8

Ersatzteilpaket, Abstreiferhalter

stripper mounting kit

pièces de rechange, jeu, pour support du dévêtisseur

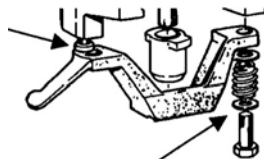

Artikel-Nr.
44006 123 18 00

Elemente der Stanzvorrichtungen • Elements of the punching attachments • Éléments des dispositifs de poinçonnage

Abstreifer • Strippers • Dévêtisseurs

Hydraulic

Abstreiferplattenaufnahme

zur Normalstanzvorrichtung und zur Sonderstanzvorrichtung 58 Ø

stripper plate holder to suit standard and oversize punching attachment up to 58 Ø

dévêtisseur à plaque pour dispositif de poinçonnage standard et dispositif jusqu'à 58 Ø

Hydraulic	Pos.	A	B	C	Artikel-Nr.
280 (bis Dezember 2011)	1	100,2	72	226	42224 560 09 30
801 • 1001 • 1250	2	100,2	72	226	44233 560 09 30

Hydraulic 280 (ab Januar 2012)	3	100,2	70	226	42224 122 30 00
--	---	-------	----	-----	-----------------

Hydraulic	Pos.	A	B	C	Artikel-Nr.
301 • 501 • 502	4	100,2	106,2	191	40613 540 05 00 M

Abstreiferplatten zu Pos. 1 – 4:

stripper plates to suit items 1 through 4:

plaques de dévêtisseur pour les postes 1 à 4 :

Ø	Artikel-Nr.
15 mm	40613 540 12 11
34 mm	40613 540 12 12 L
42 mm	40613 540 12 13
52 mm	40613 540 12 14
69 mm	40613 540 12 15

nur für Hydraulic 280	34 mm dick*	40778 560 09 01*
------------------------------	-------------	------------------

*für Materialstärke bis 6 mm

*for thin plate up to 6 mm thickness

*pour tôle mince jusqu'à 6 mm d'épaisseur

Hydraulic	Pos.	A	B	C	Artikel-Nr.
300 • 500	5	95	114,5	198	42215 551 05 00

Abstreiferplatten zu Pos. 5:

stripper plates to suit item 5:

plaques de dévêtisseur pour le poste 5 :

Ø	Artikel-Nr.
15 mm	40622 540 12 11
32 mm	40622 540 12 12
42 mm	40622 540 12 13
52 mm	40622 540 12 14
61 mm	40622 540 12 15

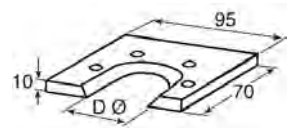
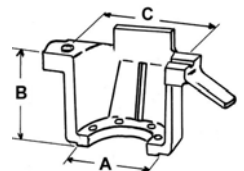
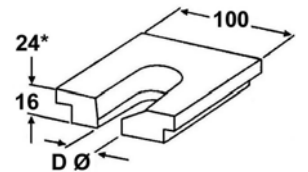
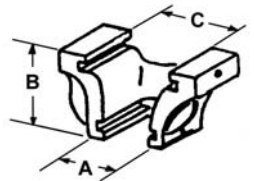
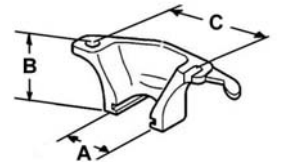
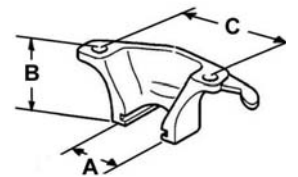

Elemente der Stanzvorrichtungen • Elements of the punching attachments • Éléments des dispositifs de poinçonnage

Abstreifer • Strippers • Dévêtisseurs

Hydraulic

Abstreifer zur Normalstanzvorrichtung

stripper to suit the standard punching attachment
 dévêtisseur pour le dispositif de poinçonnage standard

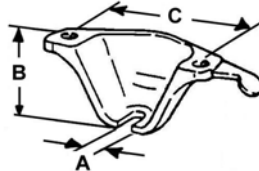

Hydraulic	Pos.	A	B	C	Artikel-Nr.
600	6	34	90	209,6	44001 540 15 05
100 • 800 • 1000	7	35	128	245,6	44081 551 05 00
1400 • 1000N • 1400N	8	44	135,4	279,6	44161 551 05 00
40 • 60N	9	34	74	226	44230 551 05 00

Abstreiferplattenaufnahme zu den

Sonderstanzvorrichtungen bis 58 Ø und 90 Ø

stripper plate holder to suit the oversize punching attachments up to 58 Ø and 90 Ø
 dévêtisseur à plaque pour les dispositifs de poinçonnage grand diamètre jusqu'à 58 Ø et 90 Ø

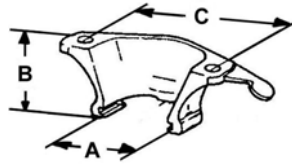

Hydraulic	Pos.	A	B	C	Artikel-Nr.
600	10	150,2	88,5	209,6	44001 199 840
100 • 800 • 1000	11	150,2	126,5	245,6	44081 199 840
1400 • 1000N • 1400N	12	150,2	134	279,6	44161 199 840
40 • 60N • 1001 • 1250	13	150,2	73,5	226	44230 199 840
300 • 500 (SV 90)	14	150,2	123	198	42215 540 14 30 L

Abstreiferplatten zu Pos. 10 - 14:

stripper plates to suit items 10 thru 14:

plaques de dévêtisseur pour les postes 10 à 14 :

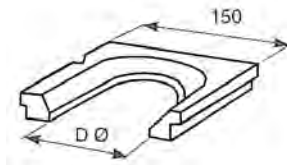

Ø	Artikel-Nr.
15	44001 198 840 1
30	44001 198 840 2
40	44001 198 840 3
50	44001 198 840 4
60	44001 198 840 5
75	44001 198 840 6
95	44001 198 840 7
105	44001 198 840 8

Ersatzteilpaket, Abstreiferhalter

stripper mounting kit
 pièces de rechange, jeu,
 pour support du dévêtisseur

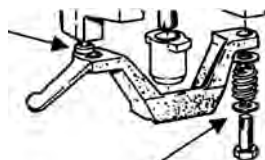

zu Pos. • to suit items • pour les postes	Artikel-Nr.
1, 2, 6, 9, 10, 13+14	44006 123 18 00
7+11	44089 123 18 00



Elemente der Stanzvorrichtungen • Elements of the punching attachments • Éléments des dispositifs de poinçonnage

Abstreifer • Strippers • Dévêtisseurs

Peddimaster

Abstreifer zur Normalstanzvorrichtung

stripper to suit the standard punching attachment
dévêtisseur pour le dispositif de poinçonnage standard

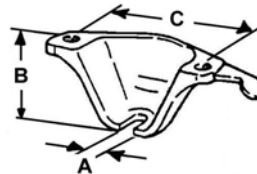

Peddimaster	Pos.	A	B	C	Artikel-Nr.
28/40 • 40/60 • 60/80 • 60/100 • 80/110	1	34	74	226	44230 551 05 00
100/160 • 110/170 • 1100/1700	2	35	128	245,6	44081 551 05 00

Abstreiferplattenaufnahme

zu den Sonderstanzvorrichtungen bis 58 Ø und 90 Ø
stripper plate holder to suit the oversize punching attachments
up to 58 Ø and 90 Ø
dévêtisseur à plaque pour les dispositifs de poinçonnage grand
diamètre jusqu'à 58 Ø et 90 Ø

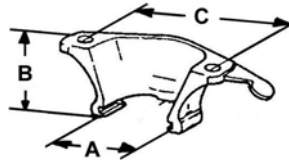

Peddimaster	Pos.	A	B	C	Artikel-Nr.
28/40 • 40/60 • 60/80 • 60/100 • 80/110	3	150,2	73,5	226	44230 199 840
100/160 • 110/170 • 1100/1700	4	150,2	126,5	245,6	44081 199 840

Abstreiferplatten zu Pos. 3 + 4:
stripper plates to suit items 3 + 4:
plaques de dévêtisseur
pour les postes 3 + 4:

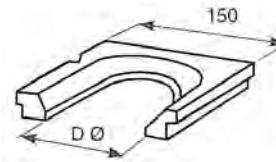

Ø	Artikel-Nr.
15	44001 198 840 1
30	44001 198 840 2
40	44001 198 840 3
50	44001 198 840 4
60	44001 198 840 5
75	44001 198 840 6
95	44001 198 840 7
105	44001 198 840 8

Abstreiferplattenaufnahme für Normalstanzvorrichtung und Sonderstanzvorrichtung bis 58 Ø

stripper plate holder to suit standard punching att. and oversize punching attachment up to 58 Ø
dévêtisseur à plaque pour dispositifs de poinçonnage standard et grand dia. jusqu'à 58

Peddimaster
800/1100

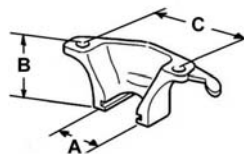

Pos.	A	B	C	Artikel-Nr.
5	100,2	72	226	44233 5 6009 30

Abstreiferplatten

stripper plates
plaques de dévêtisseur

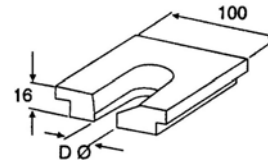

Ø	Artikel-Nr.
15	40613 540 12 11
34	40613 540 12 12 L
42	40613 540 12 13
52	40613 540 12 14
69	40613 540 12 15

Ersatzteilpaket, Abstreiferhalter

stripper mounting kit
pièces de rechange, jeu,
pour support du dévêtisseur

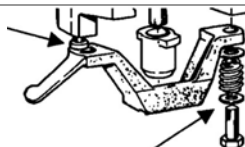

zu Pos.	Artikel-Nr.
to suit items • pour les postes	
1, 3 + 5	44006 123 18 00
2 + 4	44089 123 18 00

Elemente der Stanzvorrichtungen • Elements of the punching attachments • Éléments des dispositifs de poinçonnage

Abstreifer • Strippers • Dévêtisseurs

210 Super • 210 Forax • Stanzfix • 225 B

Abstreifer zur Normalstanzvorrichtung

stripper to suit the standard punching attachment
 dévêtisseur pour le dispositif de poinçonnage standard

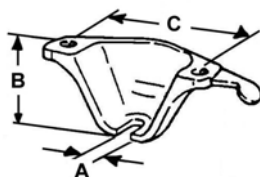

Modell	Pos.	A	B	C	Artikel-Nr.
210 Super 11+13 • 210/11+13 • 225 B 13+60 Forax 15, 25, 45, 65, 150, 250, Forax 450 • Stanzfix	1	34	90	209,6	44001 540 15 05
210 Super 16 + 20 • 210/16+20 • 225 B 80+100 Forax 80, 100, 1000	2	35	128	245,6	44081 551 05 00
210 Super 25	3	44	135,4	279,6	44161 551 05 00

Abstreiferplattenaufnahme

zu den Sonderstanzvorrichtungen bis 58 Ø und 90 Ø
 stripper plate holder to suit the oversize punching attachments
 up to 58 Ø and 90 Ø
 dévêtisseur à plaque pour les dispositifs de poinçonnage grand
 diamètre jusqu'à 58 Ø et 90 Ø

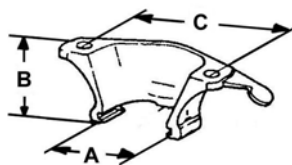

Modell	Pos.	A	B	C	Artikel-Nr.
210 Super 11+13 • 210/11+13 • 225 B 13+60 Forax 15, 25, 45, 65, 150, 250, Forax 450 • Stanzfix	4	150,2	88,5	209,6	44001 199 840
210 Super 16 + 20 • 210/16+20 • 225 B 80+100 Forax 80, 100, 1000	5	150,2	126,5	245,6	44081 199 840
210 Super 25	6	150,2	134	279,6	44161 199 840

Abstreiferplatten zu Pos. 4 - 6:
 stripper plates to suit items 4 - 6:
 plaques de dévêtisseur
 pour les postes 4 - 6:

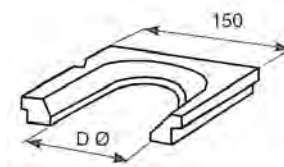

Ø	Artikel-Nr.
15	44001 198 840 1
30	44001 198 840 2
40	44001 198 840 3
50	44001 198 840 4
60	44001 198 840 5
75	44001 198 840 6
95	44001 198 840 7
105	44001 198 840 8

Ersatzteilpaket, Abstreiferhalter

stripper mounting kit
 pièces de rechange, jeu,
 pour support du dévêtisseur

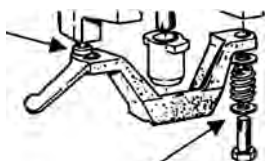

zu Pos. to suit items • pour les postes	Artikel-Nr.
1 + 4	44006 123 18 00
2 + 5	44089 123 18 00

Stanzwerkzeuge für Exzenterpressen

für den Einsatz von Stempeln und Matrizen bis \varnothing 31 mm aus dem Peddinghaus-Lagerprogramm – **Grüne Serie**

Punching attachment for an eccentric press



for using punches and dies up to 31mm \varnothing of the Peddinghaus **Green Series**

Dispositif de poinçonnage pour presses excentriques

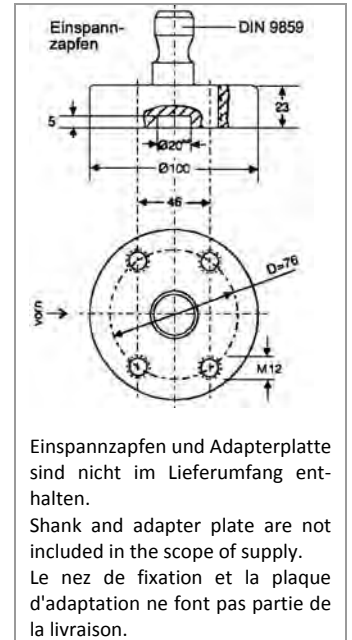
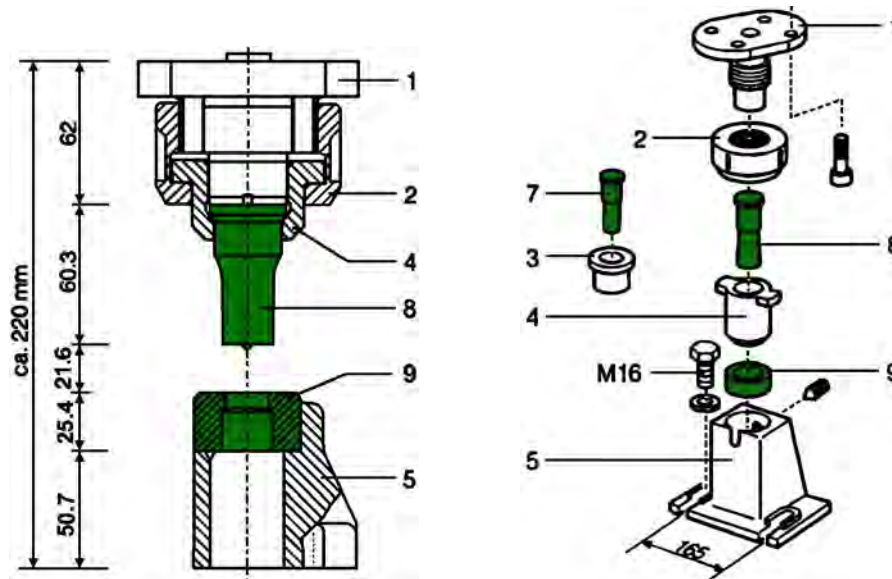
pour utiliser les poinçons et matrices Peddinghaus jusqu'à 31 mm \varnothing de la **Série verte**



Pos.	Bezeichnung	Description	Description	Artikel-Nr. • part no. • no. de réf.
1	Stempelhalter	quick-change punch holder	porte-poinçon	40615 560 01 00
2	Schnellspannmutter	quick-change locking nut	écrou de fixation	44081 198 991
3	Reduzierhülse	reducing sleeve	douille de réduction	44081 198 503
4	Schnellspanneinsatz	punch sleeve	douille de serrage rapide	42030 621 91 02
5	Matrizenhalter	die holder	porte-matrice	44041 540 16 02
6	Hakenschlüssel	hook spanner	clé de serrage	7001810 80090
1 – 6	Stanzvorrichtung für Exzenterpresse, komplett	punching attachment for eccentric press, complete	dispositif de poinçonnage pour presse ecc., complet	44041 540 16 90

7	Stempel Nr. 2 bis \varnothing 19 mm	punch no. 2 up to \varnothing 19mm	poinçon no. 2 jusqu'à \varnothing 19 mm	64002	
8	Stempel Nr. 5 bis \varnothing 32 mm	punch no. 5 up to \varnothing 32mm	poinçon no. 5 jusqu'à \varnothing 32 mm	64005	
9	Matrize Nr. 3 bis \varnothing 33,2 mm	die no. 3 up to \varnothing 33.2mm	matrice no. 3 jusqu'à \varnothing 33,2 mm	64203	

Stanzwerkzeuge für Exzenterpressen

für den Einsatz von Stempeln und Matrizen bis \varnothing 58 mm aus dem Peddinghaus-Lagerprogramm – **Blaue Serie**

Punching attachment for an eccentric press

for using punches and dies up to 58mm \varnothing of the Peddinghaus **Blue Series**

Dispositif de poinçonnage pour presses excentriques

pour utiliser les poinçons et matrices Peddinghaus jusqu'à 58 mm \varnothing de la **Série bleue**

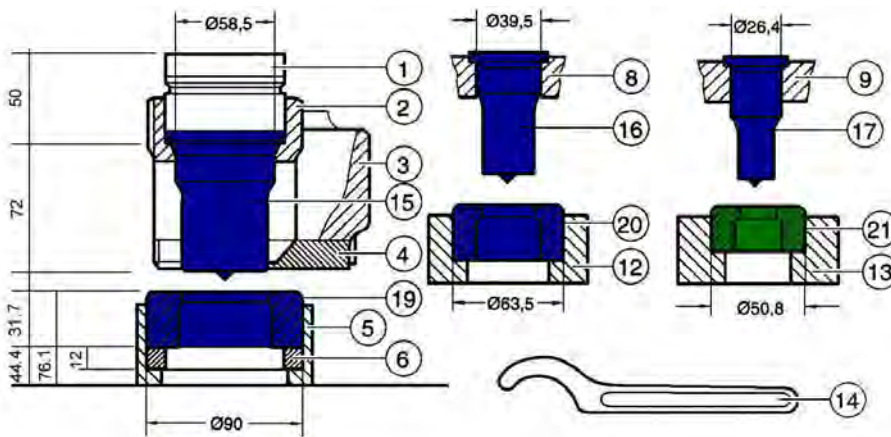

nicht im Lieferumfang enthalten:
 not included in the scope of supply:
 non compris dans la livraison:

Pos. 3 (Abstreifer) und Pos. 4 (Abstreiferplatte)
 item no. 3 (stripper) and item no. 4 (stripper plate)
 rep. 3 (dévêtisseur) et rep. 4 (plaque de dévétisseur)

nicht im Lieferumfang enthalten:
 Einspannzapfen und Adapter-platte
 not included in the scope of supply:
 shank and adapter plate
 non compris dans la livraison:
 nez de fixation et
 plaque d'adaptation

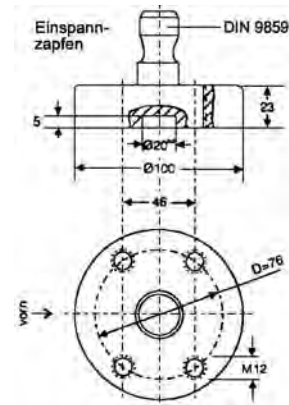

Pos.	Bezeichnung	Description	Description	Artikel-Nr. • part no. • no. de réf.
1	Stempelhalter SV58	punch holder	porte -poinçon	42200 540 12 02
2	Stempelmutter SV58	punch locking nut	écrou de fixation	44001 198 812
5	Matrizenhalter	die holder	porte-matrice	44041 199 816
6	Auflagering	support ring	bague de support	44001 198 810
8	Reduzierhülse 6 / 7	reducing sleeve 6 / 7	douille de réduction 6 / 7	44001 198 814
9	Reduzierhülse 3 / 7	reducing sleeve 3 / 7	douille de réduction 3 / 7	44001 198 813
12	Reduziereinsatz 4 / 6	reducing socket 4 / 6	bague de réduction 4 / 6	44001 199 818
13	Reduziereinsatz 3 / 6	reducing socket 3 / 6	bague de réduction 3 / 6	44081 199 817
14	Hakenschlüssel	hook spanner	clé de serrage	7001810 80090
1 – 14	Sonder-Stanzvorrichtung 58 \varnothing für Exzenterpresse, komplett	punching attachment 58 \varnothing for eccentric press, complete	dispositif de poinçonnage 58 \varnothing pour presse ecc., complet	44041 540 12 90

15	Rundstempel Nr. 7 \varnothing 40 - \varnothing 58 mm	round punch no. 7 \varnothing 40 up to \varnothing 58mm	poinçon rond no. 2 \varnothing 40 à \varnothing 58 mm	64007	
16	Rundstempel Nr. 6 \varnothing 26,5 - \varnothing 39,5 mm	round punch no. 6 \varnothing 26.5 up to \varnothing 39.5mm	poinçon rond no. 6 \varnothing 26,5 à \varnothing 39,5 mm	64006	
17	Rundstempel Nr. 3 \varnothing 5 - \varnothing 26 mm	round punch no. 3 \varnothing 5 up to \varnothing 26mm	poinçon rond no. 3 \varnothing 5 à \varnothing 26 mm	64003	
19	Rundmatrize Nr. 6 \varnothing 40,2 - \varnothing 68,7 mm	round die no. 6 \varnothing 40.2 up to \varnothing 68.7mm	matrice ronde no. 6 \varnothing 40,2 à \varnothing 68,7 mm	64206	
20	Rundmatrize Nr. 4 \varnothing 5,2 - \varnothing 40,7 mm	round die no. 4 \varnothing 5.2 up to \varnothing 40.7mm	matrice ronde no. 4 \varnothing 5,2 à \varnothing 40,7 mm	64204	
21	Rundmatrize Nr. 3 \varnothing 4,2 - \varnothing 33,2 mm	round die no. 3 \varnothing 4.2 up to \varnothing 33.2mm	matrice ronde no. 3 \varnothing 4,2 à \varnothing 33,2 mm	64203	

Das Schneidspiel zwischen Stempel und Matrize

The clearance between punch and die

Le jeu entre le poinçon et la matrice

Die Größe des zu stanzenden Loches wird durch das Ist-Maß des Stempels bestimmt. Das Ist-Maß der Matrizenöffnung ergibt sich aus dem Ist-Maß des Stempels plus dem erforderlichen Schneidspiel

Das Schneidspiel zwischen Stempel und Matrize sollte bei ca. 10 % der zu stanzenden Materialdicke liegen.

Der Lochdurchmesser darf keinesfalls kleiner sein als die Materialdicke!

The actual size of the punch determines the size of the hole to be punched. The actual size of the hole results from the combination of the actual punch size plus clearance.

The clearance (difference between punch and die size) generally used is approx. 10 % of the material thickness.

The diameter of the punch must not be smaller than the thickness of the material that is to be punched!

Le diamètre réel du poinçon définit le diamètre du trou à poinçonner. Le diamètre réel de la matrice est calculé à partir du diamètre réel du poinçon majoré du jeu.

Le jeu (différence entre les diamètres du poinçon et de la matrice) correspond en général à 10 % de l'épaisseur du matériau à poinçonner.

Le diamètre du trou à poinçonner ne doit pas être inférieur à l'épaisseur du matériau!

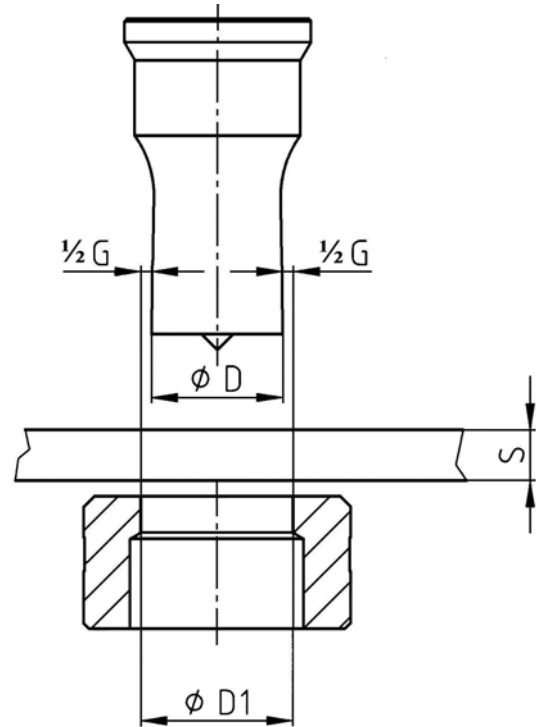

$\varnothing D$	=	Stempelmaß dimension of the punch dimension du poinçon
$\varnothing D1$	=	Matrizenmaß dimension of the die dimension de la matrice
S	=	Materialdicke material thickness épaisseur du matériau
G	=	Schneidspiel clearance jeu

Schneidspiel mm clearance mm jeu mm	G	0,2	0,7	1,2	1,7
Materialdicke mm material thickness mm épaisseur du matériau mm	S	bis 4 up to 4 jusqu'à 4	4 – 9	9 – 14	14 - 20

Stempel • Punches • Poinçons

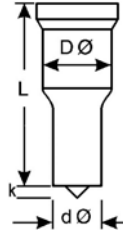

Nr.	1	4	2	5	3	6	7	11	12	13	7.1
$d \varnothing$ von • from • de	3	8	4	19,5	5	26,5	40	59	90,5	110,5	60
$d \varnothing$ bis • up to • à	14	27	19	32	26	39,5	58	90	110	130	65
$D \varnothing$	14,4	26,4	19,2	31,5	26,4	39,5	58,5	90	90	90	58
L	49,2	49,2	61	60,3	72	72	72	76,2	76,2*	76,2*	72*
k	0,8 - 3	1 - 3	0,8 - 3	3	0,8 - 3	4,5	4,5	4,5	4,5	4,5	3

*mit Stempelschaft
 *punch shaft included
 *tige de poinçon comprise

Matrizen • Dies • Matrices

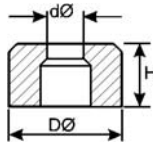

Nr.	2	7	13	16	3	8	14	4	6	20
$d \varnothing$ von • from • de	3,2	3,2	3,2	3,2	4,2	3,2	3,2	5,2	40,2	68,7
$d \varnothing$ bis • up to • à	30,7	28,2	23,7	12,7	33,2	32,7	25,2	40,7	68,7	100,2
$D \varnothing$	46,04	46,04	46,04	46,04	50,8	50,8	50,8	63,5	90	140
H	28,6	27,5 32,5	28,6	28,6	25,4	24,5 30	25,4	31,7	31,7	31,7

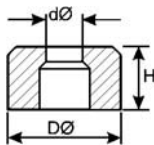

Standardmatrize
 standard die
 matrice standard

2
3
4 6 20

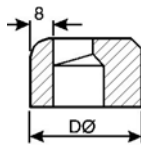

Winkelstahlmatrize
 offset flat die
 matrice décentrée

13
14

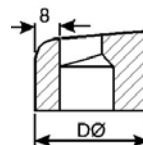

Flanschmatrize
 offset taper die
 matrice d'aile

7
8

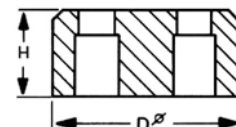

2-Loch Winkelstahlmatrize
 offset flat die, double-hole
 matrice double, décentrée

16

Streichmaß bei Exzentermatrizen

Back-marks on offset dies

Trusquinage des matrices décentrés

Winkelstahlmatrize
 offset flat die
 matrice décentrée

Nr. 13 bis 23,7 mm \varnothing

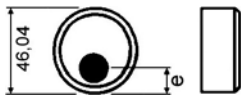

Nr. 14 bis 25,2 mm \varnothing

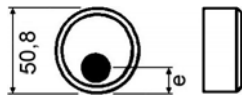

\varnothing	e	\varnothing	e	\varnothing	e	\varnothing	e
3,2	10	8,7	12	14,2	15	19,7	20
3,7	10	9,2	12	14,7	15	20,2	20
4,2	10	9,7	12	15,2	16	20,7	20
4,7	10	10,2	12	15,7	16	21,2	20
5,2	10	10,7	12	16,2	16	21,7	22
5,7	10	11,2	14	16,7	16	22,2	22
6,2	10	11,7	14	17,2	16	22,7	22
6,7	10	12,2	14	17,7	18	23,2	22
7,2	10	12,7	14	18,2	18	23,7	24
7,7	10	13,2	14	18,7	18	24,2	24
8,2	12	13,7	15	19,2	18	24,7	24

Zweiloch-Winkelstahlmatrize
 offset flat die (two holes)
 matrice double décentrée

Nr. 16 bis 12,7 mm \varnothing

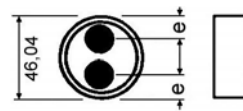

Nr. 17 bis 12,7 mm \varnothing

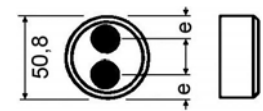

\varnothing	e	\varnothing	e
3,2	10	8,7	12
3,7	10	9,2	12
4,2	10	9,7	12
4,7	10	10,2	12
5,2	10	10,7	14
5,7	10	11,2	14
6,2	10	11,7	14
6,7	10	12,2	14
7,2	10	12,7	14
7,7	10	13,2	14
8,2	12		

Lieferzeit: ab Lager • delivery ex stock • délai: disponible

Lieferzeit: 3 Wochen • delivery: 3 weeks • délai: 3 semaines

Langloch-Winkelstahlmatrize, längs

oblong offset flat die, longitudinal
 matrice décentrée, trou oblong, sens longitudinal

Nr. 13



Nr. 14



b x L	e	b x L	e
6,2 x 14,7	13,5	10,7 x 20,7	16,4
6,2 x 25,7	18,9	11,7 x 22,7	17,4
7,2 x 26,7	19,4	11,7 x 26,7	19,4
8,2 x 26,7	19,4	13,7 x 26,7	19,4
9,7 x 14,7	13,4	14,7 x 26,7	19,4
9,7 x 26,7	19,4	16,7 x 26,7	19,4

Lieferzeit: ab Lager • delivery ex stock • délai: disponible

Langloch-Winkelstahlmatrize, quer

oblong offset flat die, transverse
 matrice décentrée, trou oblong, sens transversal

Nr. 13

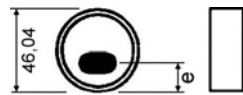

Nr. 14

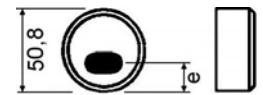

b x L	e	b x L	e
6,2 x 14,7	11	10,7 x 20,7	15
6,2 x 25,7	13,75	11,7 x 22,7	15
7,2 x 26,7	15,6	11,7 x 26,7	15,3
8,2 x 26,7	15,8	13,7 x 26,7	17
9,7 x 14,7	14,7	14,7 x 26,7	16,2
9,7 x 26,7	16	16,7 x 26,7	17,5

Lieferzeit: ab Lager • delivery ex stock • délai: disponible

Tabelle zur Ermittlung der Stanzkraft in kN
Chart for calculating the punching pressure (kN) required
Tableau pour la calcul de la puissance de poinçonnage en kN

ausgelegt für Materialien mit einer Festigkeit von 45 kN/mm²

bei VA Material ist die doppelte Stanzkraft erforderlich

for material with a tensile strength of 45 kN/mm²
 to punch stainless steel, the punching pressure has to be multiplied by 2

pour matériaux d'une résistance de 45 kN/mm²
 pour matériaux inox appliquer une puissance de poinçonnage double

Beispiel:
 Ø 20 in 9 mm = 220 kN
 bei 45 kN/mm²

bei VA Material:
 ca. 440 kN

Example:
 Ø 20 through 9 mm = 220 kN
 for 45 kN/mm²

for stainless steel:
 approx. 440 kN

Exemple:
 Ø 20 dans 9 mm = 220 kN
 pour 45 kN/mm²

pour matériau inox:
 env. 440 kN

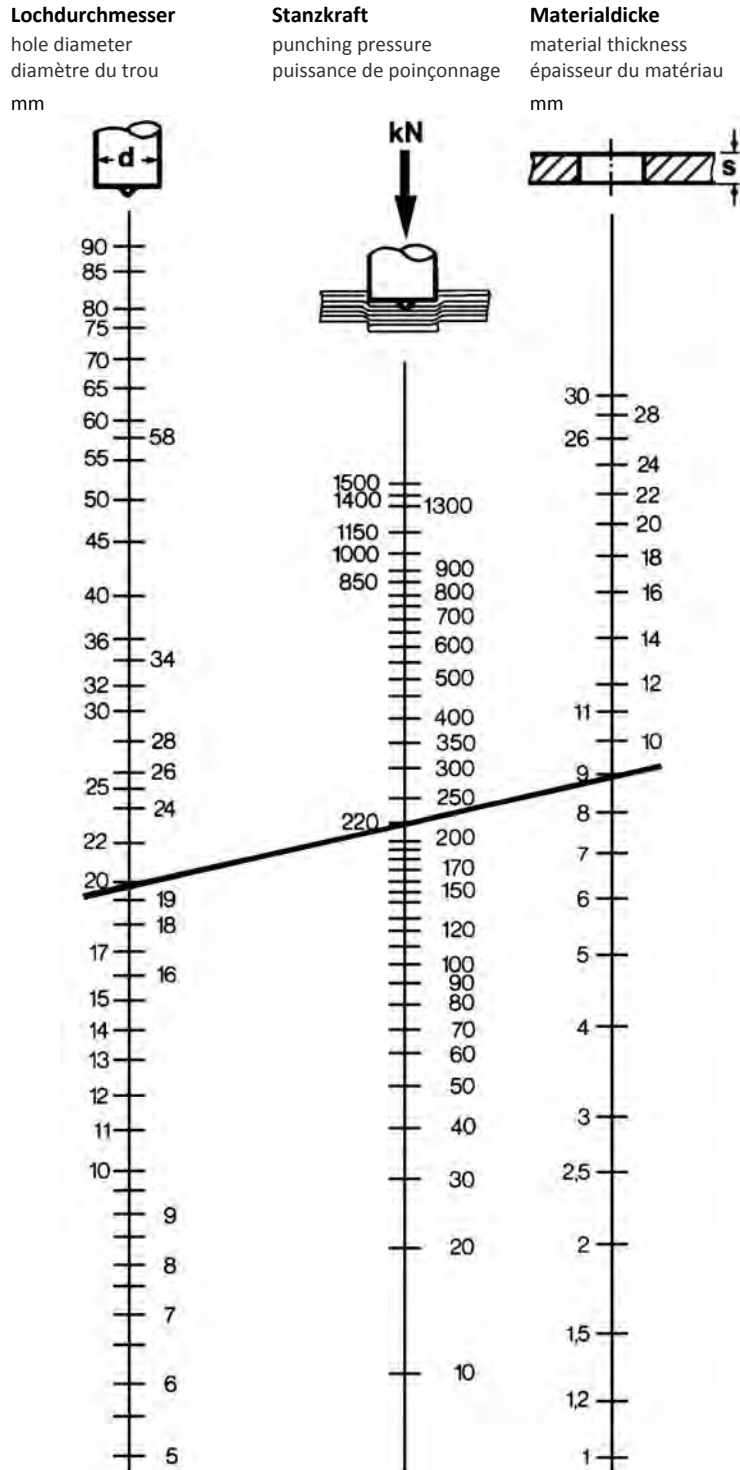

Stempel + Matrizen

Fax an: 02332 - 664646



Peddinghaus Anlagen & Maschinen GmbH

Datum : Kd. Nr. :

Anfrage :

Firma :

Straße :

PLZ - Ort :

Bearbeiter :

Email :

Angebot Auftrag Auftrag mit AB

Angebot oder AB bitte per :

Telefon :

Fax :

Maschine :

Masch. Nr. :

Artikel oder Nummer	Abmessung	Stck	Artikel oder Nummer	Abmessung	Stck

Bemerkung:

- Schneidspiel Matrizen:**
- 0,2 mm - bei einer Materialstärke bis 4 mm
 - 0,7 mm - bei einer Materialstärke von 4 bis 9 mm
 - 1,2 mm - bei einer Materialstärke von 9 bis 14 mm
 - 1,7 mm - bei einer Materialstärke von 14 bis 20 mm

Achtung !
 Der Lochdurchmesser darf keinesfalls kleiner sein als die zu bearbeitende Materialstärke.

(Unterschrift / Stempel)
 Anfragen und Bestellungen mittels diesem
 Formular, sind auch ohne Unterschrift gültig.





 Peddinghaus Anlagen & Maschinen GmbH
 Hasslinghauser Str. 156
 D-58285 Gevelsberg
 Tel. +49 (0) 2332 – 6646-0
 Fax +49 (0) 2332 – 6646-40
 mail@peddy.de
 www.peddy.de

 Paul Ferd. Peddinghaus GmbH
 Peddinghaus Corporation Gruppe
 Hasslinghauser Str. 156
 D-58285 Gevelsberg
 Tel. +49 (0) 2332 – 72-0
 Fax +49 (0) 2332 – 72-208
 info@peddinghaus-pfp.de
 www.peddinghaus-pfp.de

 Peddinghaus Española, S.A.
 Pol. Industrial Gojain
 01170 Legutiano-Alava, España
 tel. +34 945 46 53 70
 fax +34 945 46 55 26
 pesa@peddinghaus.es
 www.peddinghaus.es

 P.A.M. Peddinghaus France
 Pierre Klein
 43, rue Balzac
 67170 Brumath, Frankreich
 tél. 03 88 51 17 14
 fax 03 88 51 17 14
 peddinghaus@wanadoo.fr
 www.peddy.de

 Peddinghaus Corporation
 300 N. Washington Avenue
 Bradley, IL 60915, U.S.A.
 tel. +1 815 937 3800
 fax +1 815 937 4003
 info@peddinghaus.com
 www.peddinghaus.com

 Peddinghaus Corporation U.K. Ltd.
 Unit 6 Queensway Link
 Stafford Park 17
 Telford, Shropshire TF3 3DN, U.K.
 tel. 01952 200377
 fax 01952 292877
 info@peddinghaus.co.uk
 www.peddinghaus.co.uk