

**Rote Serie • Red Series • Série rouge**

für ältere Modelle:  
for older machine types:  
pour modèles plus anciens:

**Peddicat 360**  
**Peddiworker 400 • 500 • 600 • 800**  
**Peddimaster 450M • 28/40 • 40/60 • 60/80 • 60/100 • 80/110**  
**Hydraulic 40 • 60N • 300 • 500 • 600**  
**210 Super 11 • 13, 210 Standard 11 • 13**  
**Forax 15 • 25 • 45 • 65 • 150 • 250 • 450**  
**Stanzfix**  
**225 B/11 • 13 • 45 • 60**  
**225 H/11 • 13**

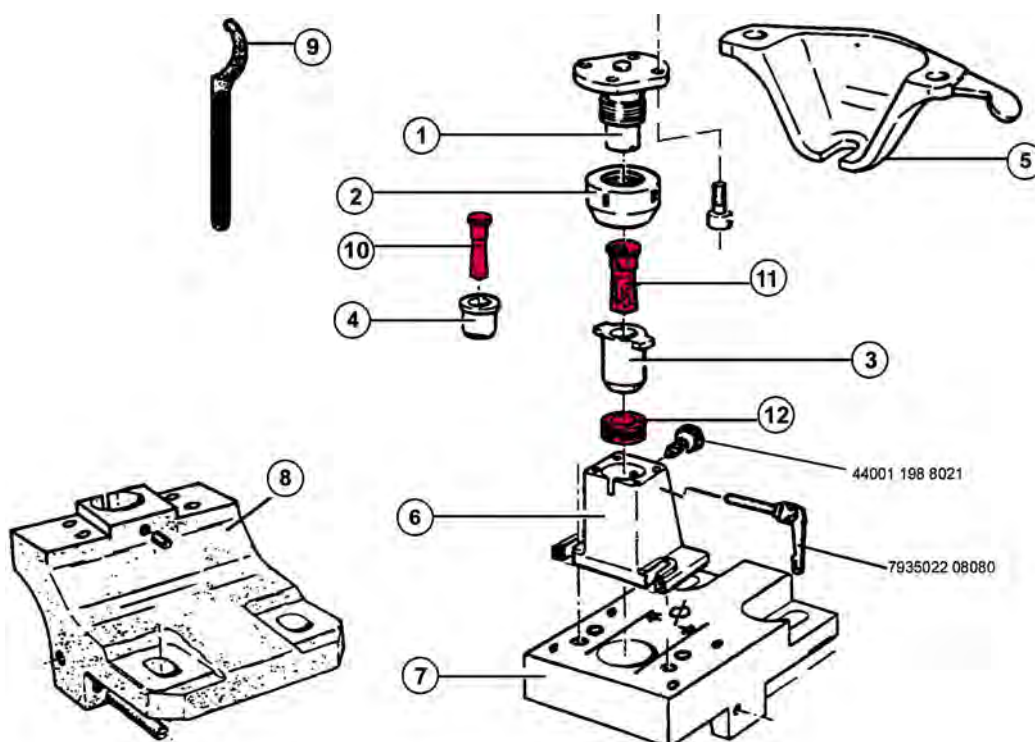

Stempel und Matrizen zur Schnellwechsellvorrichtung  
Punches and dies for the quick-change punching attachment  
Poinçons et matrices pour utilisation dans le dispositif de serrage rapide du poinçon



# Peddinghaus

Peddinghaus Anlagen & Maschinen GmbH

Peddinghaus Anlagen & Maschinen GmbH  
 Hasslinghauser Str. 156 • D-58285 Gevelsberg  
 Tel. +49 (0) 2332 / 6646-21/22/23  
 Fax +49 (0) 2332 / 6646-46  
 teile-pam@peddy.de • www.peddy.de

## Rote Serie • Red Series • Série rouge

**Rundstempel**  
 round punch  
 poinçon rond

**Rundstempel**  
 round punch  
 poinçon rond

**Rundmatrize**  
 round die  
 matrice ronde

**Rundmatrize**  
 round die  
 matrice ronde

**Winkelstahlmatrize**  
 offset flat die  
 matrice ronde décentrée

**Nr. 1**

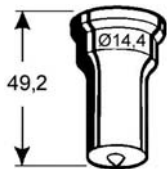

**Nr. 4**

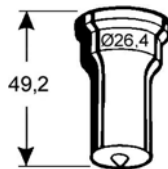

**Nr. 2**

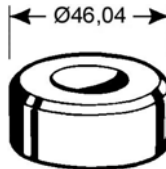

**Nr. 2**

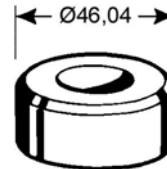

**Nr. 13**

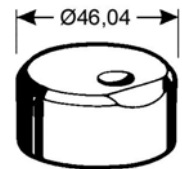

Artikel-Nr.	Artikel-Nr.	Artikel-Nr.	Artikel-Nr.	Artikel-Nr.
3,0 64001 1030	8,0 64004 1080	3,2 64202 1032	19,2 64202 1192	5,2 64213 1052
3,2 64001 1032	8,5 64004 1085	3,4 64202 1034	19,7 64202 1197	5,7 64213 1057
3,5 64001 1035	9,0 64004 1090	3,7 64202 1037	20,2 64202 1202	6,2 64213 1062
4,0 64001 1040	9,5 64004 1095	4,2 64202 1042	20,7 64202 1207	6,7 64213 1067
4,2 64001 1042	10,0 64004 1100	4,4 64202 1044	21,2 64202 1212	7,2 64213 1072
4,5 64001 1045	10,5 64004 1105	4,7 64202 1047	21,7 64202 1217	7,7 64213 1077
5,0 64001 1050	11,0 64004 1110	5,2 64202 1052	22,2 64202 1222	8,2 64213 1082
5,5 64001 1055	11,5 64004 1115	5,7 64202 1057	22,7 64202 1227	8,7 64213 1087
6,0 64001 1060	12,0 64004 1120	6,2 64202 1062	23,2 64202 1232	9,2 64213 1092
6,5 64001 1065	12,5 64004 1125	6,7 64202 1067	23,7 64202 1237	9,7 64213 1097
7,0 64001 1070	13,0 64004 1130	7,2 64202 1072	24,2 64202 1242	10,2 64213 1102
7,5 64001 1075	13,5 64004 1135	7,7 64202 1077	24,7 64202 1247	10,7 64213 1107
8,0 64001 1080	14,0 64004 1140	8,2 64202 1082	25,2 64202 1252	11,2 64213 1112
8,5 64001 1085	14,5 64004 1145	8,7 64202 1087	25,7 64202 1257	11,7 64213 1117
9,0 64001 1090	15,0 64004 1150	9,2 64202 1092	26,2 64202 1262	12,2 64213 1122
9,5 64001 1095	15,5 64004 1155	9,7 64202 1097	26,7 64202 1267	12,7 64213 1127
10,0 64001 1100	16,0 64004 1160	10,2 64202 1102	27,2 64202 1272	13,2 64213 1132
10,5 64001 1105	16,5 64004 1165	10,7 64202 1107	27,7 64202 1277	13,7 64213 1137
11,0 64001 1110	17,0 64004 1170	11,2 64202 1112	28,2 64202 1282	14,2 64213 1142
11,5 64001 1115	17,5 64004 1175	11,7 64202 1117	28,7 64202 1287	14,7 64213 1147
12,0 64001 1120	18,0 64004 1180	12,2 64202 1122	29,2 64202 1292	15,2 64213 1152
12,5 64001 1125	18,5 64004 1185	12,7 64202 1127	29,7 64202 1297	15,7 64213 1157
13,0 64001 1130	19,0 64004 1190	13,2 64202 1132	30,2 64202 1302	16,2 64213 1162
13,5 64001 1135	19,5 64004 1195	13,7 64202 1137	30,7 64202 1307	16,7 64213 1167
14,0 64001 1140	20,0 64004 1200	14,2 64202 1142		17,2 64213 1172
	20,5 64004 1205	14,7 64202 1147		17,7 64213 1177
	21,0 64004 1210	15,2 64202 1152		18,2 64213 1182
	21,5 64004 1215	15,7 64202 1157		18,7 64213 1187
	22,0 64004 1220	16,2 64202 1162		19,2 64213 1192
	22,5 64004 1225	16,7 64202 1167		19,7 64213 1197
	23,0 64004 1230	17,2 64202 1172		20,2 64213 1202
	23,5 64004 1235	17,7 64202 1177		20,7 64213 1207
	24,0 64004 1240	18,2 64202 1182		21,2 64213 1212
	24,5 64004 1245	18,7 64202 1187		21,7 64213 1217
	25,0 64004 1250			22,2 64213 1222
	25,5 64004 1255			22,7 64213 1227
	26,0 64004 1260			
	26,5 64004 1265			
	27,0 64004 1270			



Reduzierhülse 1/4  
 reducing sleeve  
 réducteur

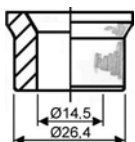

44001 198 503

Stempel-Übergröße:  
 oversize punch:  
 poinçon surdimension:

28,0 64004 1280  
 29,0 64004 1290  
 30,0 64004 1300

zusätzlich erforderlich:  
 additionally required:  
 nécessaire en plus:

Spezial-Schnellspanneinsatz  
 special quick-change punch sleeve  
 douille de serrage rapide spéciale  
 44001 6 3523 01



Schneidspiel: Seite  
 clearance: see page  
 jeu: voir page  
 71



Streichmaß: Seite  
 back marks: see page  
 trusquinage: voir page  
 73

**Rote Serie • Red Series • Série rouge**

**Vierkantstempel**  
square punch  
poignon carré

**Vierkantmatrize**  
square die  
matrice carrée

**Langlochstempel**  
oblong punch  
poignon oblong

**Langlochmatrize**  
oblong die  
matrice oblongue

**Nr. 1**

**Nr. 2**

**Nr. 1**

**Nr. 2**

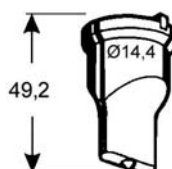
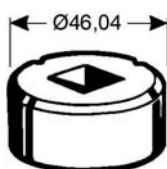
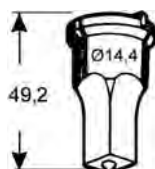

Vierkantstempel		Vierkantmatrize		Langlochstempel		Langlochmatrize	
Nr. 1		Nr. 2		Nr. 1		Nr. 2	
Artikel-Nr.		Artikel-Nr.		Artikel-Nr.		Artikel-Nr.	
4,0	64001 2040	4,2	64202 2042	5,0 × 10	64001 3050100	5,2 × 10,2	64202 3 052102
5,0	64001 2050	5,2	64202 2052			5,7 × 10,7	64202 3 057107
6,0	64001 2060	6,2	64202 2062	5,0 × 14	64001 3050140	5,2 × 14,2	64202 3 052142
7,0	64001 2070	6,7	64202 2067			5,7 × 14,7	64202 3 057147
8,0	64001 2080	7,2	64202 2072	5,5 × 10	64001 3055100	5,7 × 10,2	64202 3 057102
9,0	64001 2090	7,7	64202 2077			6,2 × 10,7	64202 3 062107
10,0	64001 2100	8,2	64202 2082	5,5 × 14	64001 3055140	5,7 × 14,2	64202 3 057142
		8,7	64202 2087			6,2 × 14,7	64202 3 062147
		9,2	64202 2092	6,5 × 12	64001 3065120	6,7 × 12,2	64202 3 067122
		9,7	64202 2097			7,2 × 12,7	64202 3 072127
		10,2	64202 2102	7,5 × 14	64001 3075140	7,7 × 14,2	64202 3 077142
		10,7	64202 2107			8,2 × 14,7	64202 3 082147
		11,2	64202 2112	9,0 × 14	64001 3090140	9,2 × 14,2	64202 3 092142
		11,7	64202 2117			9,7 × 14,7	64202 3 097147
		12,2	64202 2122	10,0 × 14	64001 3100140	10,2 × 14,2	64202 3 102142
		12,7	64202 2127			10,7 × 14,7	64202 3 107147
		13,2	64202 2132				
		13,7	64202 2137				
		14,2	64202 2142				
		14,7	64202 2147				
		15,2	64202 2152				
		15,7	64202 2157				
		16,2	64202 2162				
		16,7	64202 2167				
		17,2	64202 2172				
		17,7	64202 2177				
		18,2	64202 2182				
		18,7	64202 2187				
		19,2	64202 2192				
		19,7	64202 2197				
		20,2	64202 2202				
		20,7	64202 2207				
		21,2	64202 2212				
		21,7	64202 2217				

**Vierkantstempel**  
square punch  
poignon carré

**Nr. 4**

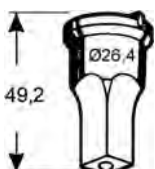

Artikel-Nr.	
11,0	64004 2110
12,0	64004 2120
13,0	64004 2130
14,0	64004 2140
15,0	64004 2150
16,0	64004 2160
17,0	64004 2170
18,0	64004 2180
19,0	64004 2190
20,0*	64004 2200
21,0*	64004 2210

\* Übergröße,  
zusätzlich erforderlich:  
\* oversize,  
additionally required:  
\* surdimension,  
nécessaire en plus :



65004 8087 01

Spezial-Schnellspanneinsatz  
special quick-change punch sleeve  
douille de serrage rapide spéciale

Materialdicke material thickness épaisseur du matériau bis 4 mm	Schneidspiel clearance jeu	siehe Seite see page voir page
4 – 9 mm	0,2 mm	
9 – 14 mm	0,7 mm	71
	1,2 mm	



# Peddinghaus

Peddinghaus Anlagen & Maschinen GmbH

Peddinghaus Anlagen & Maschinen GmbH  
Hasslinghauser Str. 156 • D-58285 Gevelsberg  
Tel. +49 (0) 2332 / 6646-21/22/23  
Fax +49 (0) 2332 / 6646-46  
teile-pam@peddy.de • www.peddy.de

## Rote Serie • Red Series • Série rouge

**Langlochstempel**  
oblong punch  
poinçon oblong

**Langlochmatrize**  
oblong die  
matrice oblongue

**Langloch-  
Winkelstahlmatrize, längs**  
oblong offset die, longitudinal  
matrice oblongue décentrée,  
sens longitudinal

**Langloch-  
Winkelstahlmatrize, quer**  
oblong offset die, transverse  
matrice oblongue décentrée,  
sens transversal





**Nr. 4**

**Nr. 2**

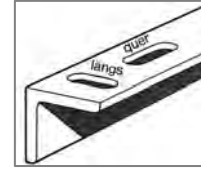
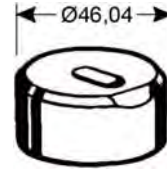
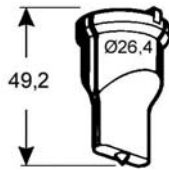
**Nr. 13**

**Nr. 13**



 Artikel-Nr.	 Artikel-Nr.	 Artikel-Nr.	 Artikel-Nr.
<b>5,5 × 19</b> 64004 3055190	<b>5,7 × 19,2</b> 64202 3 057192	<b>6,2 × 14,7</b> 64213 3 062147 <b>9,7 × 14,7</b> 64213 3 097147	<b>6,2 × 14,7</b> 64213 4 062147 <b>9,7 × 14,7</b> 64213 4 097147
<b>5,5 × 25</b> 64004 3055250	<b>6,2 × 19,7</b> 64202 3 062197		
<b>6,5 × 18</b> 64004 3065180	<b>5,7 × 25,2</b> 64202 3 057252	<b>6,2 × 25,7</b> 64213 3 062257	<b>6,2 × 25,7</b> 64213 4 062257
<b>6,5 × 26</b> 64004 3065260	<b>6,2 × 25,7</b> 64202 3 062257		
<b>7,5 × 21</b> 64004 3075210	<b>6,7 × 18,2</b> 64202 3 067182	<b>7,2 × 26,7</b> 64213 3 072267	<b>7,2 × 26,7</b> 64213 4 072267
<b>7,5 × 26</b> 64004 3075260	<b>7,2 × 18,7</b> 64202 3 072187		
<b>9,0 × 18</b> 64004 3090180	<b>6,7 × 26,2</b> 64202 3 067262	<b>8,2 × 26,7</b> 64213 3 082267	<b>8,2 × 26,7</b> 64213 4 082267
<b>9,0 × 26</b> 64004 3090260	<b>7,2 × 26,7</b> 64202 3 072267		
<b>10,0 × 20</b> 64004 3100200	<b>7,7 × 21,2</b> 64202 3 077212	<b>9,7 × 26,7</b> 64213 3 097267	<b>9,7 × 26,7</b> 64213 4 097267
<b>10,0 × 26</b> 64004 3100260	<b>8,2 × 21,7</b> 64202 3 082217		
<b>11,0 × 22</b> 64004 3110220	<b>7,7 × 26,2</b> 64202 3 077262	<b>10,7 × 20,7</b> 64213 3 107207	<b>10,7 × 20,7</b> 64213 4 107207
<b>11,0 × 26</b> 64004 3110260	<b>8,2 × 26,7</b> 64202 3 082267		
<b>12,0 × 24</b> 64004 3120240	<b>9,2 × 18,2</b> 64202 3 092182	<b>11,7 × 22,7</b> 64213 3 117227	<b>11,7 × 22,7</b> 64213 4 117227
<b>13,0 × 26</b> 64004 3130260	<b>9,7 × 18,7</b> 64202 3 097187	<b>11,7 × 26,7</b> 64213 3 117267	<b>11,7 × 26,7</b> 64213 4 117267
<b>14,0 × 26</b> 64004 3140260	<b>9,2 × 26,2</b> 64202 3 092262		
<b>16,0 × 26</b> 64004 3160260	<b>9,7 × 26,7</b> 64202 3 097267	<b>13,7 × 26,7</b> 64213 3 137267	<b>13,7 × 26,7</b> 64213 4 137267
<b>18,0 × 26</b> 64004 3180260	<b>10,2 × 20,2</b> 64202 3 102202	<b>14,7 × 26,7</b> 64213 3 147267	<b>14,7 × 26,7</b> 64213 4 147267
	<b>10,7 × 20,7</b> 64202 3 107207		
	<b>10,2 × 26,2</b> 64202 3 102262	<b>16,7 × 26,7</b> 64213 3 167267	<b>16,7 × 26,7</b> 64213 4 167267
	<b>10,7 × 26,7</b> 64202 3 107267		
	<b>11,2 × 22,2</b> 64202 3 112222		
	<b>11,7 × 22,7</b> 64202 3 117227		
	<b>11,2 × 26,2</b> 64202 3 112262		
	<b>11,7 × 26,7</b> 64202 3 117267		
	<b>12,2 × 24,2</b> 64202 3 122242		
	<b>12,7 × 24,7</b> 64202 3 127247		
	<b>13,2 × 26,2</b> 64202 3 132262		
	<b>13,7 × 26,7</b> 64202 3 137267		
	<b>14,2 × 26,2</b> 64202 3 142262		
	<b>14,7 × 26,7</b> 64202 3 147267		
	<b>16,2 × 26,2</b> 64202 3 162262		
	<b>16,7 × 26,7</b> 64202 3 167267		
	<b>18,2 × 26,2</b> 64202 3 182262		
	<b>18,7 × 26,7</b> 64202 3 187267		



Streichmaß bei Exzentermatrizen  
back marks on offset dies  
trusquinage, matrices décentrées

siehe Seite  
see page  
voir page  
73

**Rote Serie • Red Series • Série rouge**

**Rechteckstempel**  
 rectangular punch  
 poinçon rectangulaire

**Rechteckmatrize**  
 rectangular die  
 matrice rectangulaire

**Eckenabrundstempel**  
 corner radiusing punch  
 poinçon pour arrondir les angles

**Eckenabrundmatrize**  
 corner radiusing die  
 matrice pour arrondir les angles

**Nr. 4      Nr. 2      Nr. 4      Nr. 2**

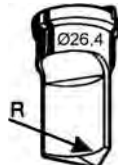
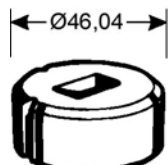
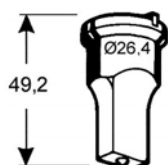

Artikel-Nr.		Artikel-Nr.		Artikel-Nr.		Artikel-Nr.	
<b>5,0 × 15</b>	64004 5 050150	<b>5,2 × 15,2</b>	64202 5 052152	<b>Radius 5</b>	65004 37 00050	<b>Radius 5</b>	65202 37 00050
		<b>5,7 × 15,7</b>	64202 5 057157	<b>10</b>	65004 37 00100	<b>10</b>	65202 37 00100
<b>5,0 × 20</b>	64004 5 050200	<b>5,2 × 20,2</b>	64202 5 052202	<b>14</b>	65004 37 00140	<b>14</b>	65202 37 00140
		<b>5,7 × 20,7</b>	64202 5 057207	<b>Drehriegelstempel</b> hasp hole punch poinçon trou d'espagnolette		<b>Drehriegelmatrize</b> hasp hole die matrice trou d'espagnolette	
<b>6,0 × 24</b>	64004 5 060240	<b>6,2 × 24,2</b>	64202 5 062242	<b>Nr. 4</b>		<b>Nr. 2</b>	
		<b>6,7 × 24,7</b>	64202 5 067247				
<b>8,0 × 16</b>	64004 5 080160	<b>8,2 × 16,2</b>	64202 5 082162	Artikel-Nr.		Artikel-Nr.	
		<b>8,7 × 16,7</b>	64202 5 087167	Ø 22,2 × 20,3    65004 38 222203		Ø 22,4 × 20,5    65202 38 224205	
<b>8,0 × 24</b>	64004 5 080240	<b>8,2 × 24,2</b>	64202 5 082242				
		<b>8,7 × 24,7</b>	64202 5 087247				
<b>9,0 × 24</b>	64004 5 090240	<b>9,2 × 24,2</b>	64202 5 092242				
		<b>9,7 × 24,7</b>	64202 5 097247				
<b>10,0 × 20</b>	64004 5 100200	<b>10,2 × 20,2</b>	64202 5 102202				
		<b>10,7 × 20,7</b>	64202 5 107207				
<b>11,0 × 22</b>	64004 5 110220	<b>11,2 × 22,2</b>	64202 5 112222				
		<b>11,7 × 22,7</b>	64202 5 117227				
<b>12,0 × 22</b>	64004 5 120220	<b>12,2 × 22,2</b>	64202 5 122222				
		<b>12,7 × 22,7</b>	64202 5 127227				
<b>14,0 × 20</b>	64004 5 140200	<b>14,2 × 20,2</b>	64202 5 142202				
		<b>14,7 × 20,7</b>	64202 5 147207				
<b>16,0 × 20</b>	64004 5 160200	<b>16,2 × 20,2</b>	64202 5 162202				
		<b>16,7 × 20,7</b>	64202 5 167207				

Materialdicke  
 material thickness  
 épaisseur du matériau  
 bis 4 mm  
 4 – 9 mm

Schneidspiel  
 clearance  
 jeu  
 0,2 mm  
 0,7 mm

siehe Seite  
 see page  
 voir page  
 71

**Rote Serie • Red Series • Série rouge**

**Spezial-Stempel zum Stanzen von VA-Material  
 Special Punches for Punching Stainless Steel  
 Poinçons spéciaux pour poinçonner du matériau inox**

**Spezial-Rundstempel  
 special round punch  
 poinçon rond spécial**

Rundmatrize (Standard)  
 round die (standard)  
 matrice ronde (standard)

**Spezial-Langlochstempel  
 special oblong punch  
 poinçon oblong spécial**

Langlochmatrize (Standard)  
 oblong die (standard)  
 matrice oblongue (standard)





**Nr. 1**

**Nr. 2**

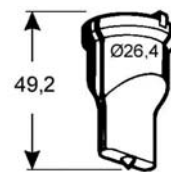
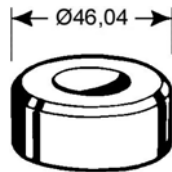
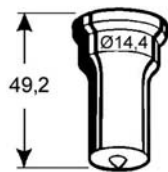
**Nr. 4**

**Nr. 2**



	Artikel-Nr.		Artikel-Nr.		Artikel-Nr.		Artikel-Nr.
<b>3,0</b>	P-65001 8004 030	<b>3,2</b>	64202 1032	<b>9,0 × 26,0</b>	P-65004 8008 01	<b>9,7 × 26,7</b>	64202 3 097267
<b>4,0</b>	P-65001 8004 040	<b>3,7</b>	64202 1037	<b>11,0 × 26,0</b>	P-65004 8008 02	<b>11,7 × 26,7</b>	64202 3 117267
<b>4,5</b>	P-65001 8004 045	<b>4,2</b>	64202 1042			<b>12,2 × 27,2</b>	64202 3 122272
<b>5,0</b>	P-65001 8004 050	<b>4,7</b>	64202 1047				
<b>6,0</b>	P-65001 8004 060	<b>5,2</b>	64202 1052	<b>13,0 × 26,0</b>	P-65004 8008 03	<b>13,7 × 26,7</b>	64202 3 137267
<b>7,0</b>	P-65001 8004 070	<b>5,7</b>	64202 1057			<b>14,2 × 27,2</b>	64202 3 142272
<b>8,0</b>	P-65001 8004 080	<b>6,2</b>	64202 1062				
<b>9,0</b>	P-65001 8004 090	<b>6,7</b>	64202 1067				
<b>10,0</b>	P-65001 8004 100	<b>7,2</b>	64202 1072				
<b>11,0</b>	P-65001 8004 110	<b>7,7</b>	64202 1077				
<b>12,0</b>	P-65001 8004 120	<b>8,2</b>	64202 1072				
<b>13,0</b>	P-65001 8004 130	<b>8,7</b>	64202 1077				
<b>14,0</b>	P-65001 8004 140	<b>9,2</b>	64202 1092				
		<b>9,7</b>	64202 1097				
		<b>10,2</b>	64202 1102				
		<b>10,7</b>	64202 1107				
		<b>11,2</b>	64202 1112				
		<b>11,7</b>	64202 1117				
		<b>12,2</b>	64202 1122				
		<b>12,7</b>	64202 1127				
		<b>13,2</b>	64202 1132				
		<b>13,7</b>	64202 1137				
		<b>14,2</b>	64202 1142				
		<b>14,7</b>	64202 1147				
		<b>15,2</b>	64202 1152				

Materialdicke  
 material thickness  
 épaisseur du matériau  
 bis 4 mm  
 4 – 9 mm  
 9 – 14 mm

Schneidspiel  
 clearance  
 jeu  
 0,2 mm  
 0,7 mm  
 1,2 mm

siehe Seite  
 see page  
 voir page

71